



## INVITATION TO BID

Goods & Services



# ITB 23-02-01 EAST END OF 172<sup>nd</sup> STREET ROADWAY AND DRAINAGE IMPROVEMENTS

<b>RELEASE DATE:</b>	<b>FEBRUARY 22, 2023</b>
<b>NON-MANDATORY PRE-BID MEETING</b>	<b>MONDAY, MARCH 13, 2023 AT 11:00 AM SUNNY ISLES BEACH GOVERNMENT CENTER 18070 COLLINS AVENUE, 1<sup>ST</sup> FLOOR CONFERENCE SUNNY ISLES BEACH, FLORIDA 33160</b>
<b>ALL QUESTIONS DUE:</b>	<b>MARCH 17, 2023 AT 5:00 PM</b>
<b>SUBMISSION DUE DATE:</b>	<b>TUESDAY, MARCH 28, 2023 AT 11:00 AM</b>
<b>SUBMIT <u>SEALED</u> BIDS TO:</b>  Envelope must clearly provide your firm's name, phone # and contact information and must be labeled with the RFP # and name.	<b>CITY CLERK SUNNY ISLES BEACH GOVERNMENT CENTER 18070 COLLINS AVENUE, 1<sup>ST</sup> FLOOR SUNNY ISLES BEACH, FLORIDA 33160</b>



TABLE OF CONTENTS	PAGE NO.
<b>TABLE OF CONTENTS</b>	
<a href="#">LEGAL ADVERTISEMENT/ NOTICE TO FIRM</a>	3
<a href="#">GENERAL TERMS &amp; CONDITIONS</a>	4
<a href="#">SPECIAL TERMS &amp; CONDITIONS</a>	10
<a href="#">SCOPE OF WORK / TECHNICAL SPECIFICATIONS</a>	22
<a href="#">PROPOSAL FORMAT</a>	23
<a href="#">BID SUBMITTAL FORM</a>	32
<b>ATTACHMENTS - MUST BE REVIEWED BY YOUR FIRM</b>	
ATTACHMENT A - PLANS	
ATTACHMENT B - PRICE SHEET	
<b>AFFIDAVITS</b>	
BID BOND AND PERFORMANCE BOND	
NON-COLLUSIVE AFFIDAVIT	
PUBLIC ENTITY CRIMES	
EQUAL OPPORTUNITY / AFFIRMATIVE ACTION STATEMENT	
CONFLICT OF INTEREST STATEMENT	
DISPUTE DISCLOSURE FORM	
ANTI-KICKBACK AFFIDAVIT	
ANTI-BOYCOTT CERTIFICATION	
E-VERIFY AFFIDAVIT	



**LEGAL ADVERTISEMENT  
NOTICE TO FIRM**

NOTICE IS HEREBY GIVEN that the City of Sunny Isles Beach is seeking sealed Bids for the following work as specified.

**EAST END OF 172ND STREET ROADWAY AND DRAINAGE IMPROVEMENTS  
INVITATION TO BID NO. 23-02-01**

The Specifications for this INVITATION TO BID are available from DemandStar by calling (800) 711-1712 or by accessing their website at [www.demandstar.com](http://www.demandstar.com). The Bid Specifications may also be examined at the City of Sunny Isles Beach – Office of the City Clerk. Vendors who obtain the Bid Specifications from sources other than DemandStar or the City of Sunny Isles Beach are cautioned that their Bid response package may be incomplete. Any addenda will be posted and disseminated by DemandStar at least five days prior to the submittal date to all vendors who are listed on the official list.

Sealed Bids will be received by the City Clerk no later than **11:00 AM ON TUESDAY, MARCH 28, 2023** at the Sunny Isles Beach Government Center located at 18070 Collins Avenue, 4th floor, Sunny Isles Beach, Florida, 33160. Bids received after this time will not be considered. The City is under no obligation to return Bids. Timely submitted Bids will be opened publicly and names of firms read aloud at this time. The envelope containing the sealed bid must be clearly marked:

**“IMPORTANT, BID ENCLOSED SUBMIT TO CITY CLERK’S OFFICE”  
INVITATION TO BID NO. 23-02-01  
EAST END OF 172nd STREET ROADWAY AND DRAINAGE IMPROVEMENTS  
OPENING DATE AND TIME: TUESDAY, MARCH 28, 2023 AT 11:00 AM**

The Owner reserves the right to reject any or all Bids, with or without cause, to waive technical errors and informalities, and to accept the Bid, which best serves the interest of, and represents the best value to, the Owner in conformity with the criteria set forth in Section 62-8 of the Code of Ordinances of the City of Sunny Isles Beach. **Potential and actual proposers shall not solicit or otherwise communicate in any manner whatsoever, directly or indirectly, with the City Council, City Manager, evaluation committee members, or City staff, other than Purchasing Division personnel, regarding this ITB from the time of the ITB initial release through the award.**

The City will host a non-mandatory pre-bid conference on **MONDAY, MARCH 13, 2023 AT 11:00 AM** at the City of Sunny Isles Beach Government Center, 1<sup>ST</sup> Floor Conference Room.

All questions regarding this bid shall be directed in writing by **MARCH 17, 2023 AT 5:00 PM**. Questions may be submitted via email to: [Purchasing@sibfl.net](mailto:Purchasing@sibfl.net).

*Pursuant to Florida Statutes 119.071, sealed bids, proposals or replies by an agency pursuant to a competitive solicitation are exempt from inspection until such time as the agency provides notice of an intended decision or until thirty (30) days after the opening of the bids, proposals, or final replies, whichever is earlier.*

Mauricio Betancur, CMC, City Clerk



## SECTION 1

### INSTRUCTIONS TO BIDDER / GENERAL TERMS AND CONDITIONS

THESE INSTRUCTIONS ARE STANDARD FOR ALL BID COMMODITIES/SERVICES ISSUED BY THE CITY OF SUNNY ISLES BEACH. THE CITY OF SUNNY ISLES BEACH MAY DELETE, SUPERSEDE OR MODIFY ANY OF THESE STANDARD INSTRUCTIONS FOR A PARTICULAR CONTRACT BY INDICATING SUCH CHANGE IN SPECIAL INSTRUCTIONS TO BIDDERS OR IN THE BID SHEETS. ANY AND ALL SPECIAL CONDITIONS THAT MAY VARY FROM THE GENERAL CONDITIONS SHALL HAVE PRECEDENCE. BIDDER AGREES THAT THE PROVISIONS INCLUDED WITHIN THIS BID OR RFP SHALL PREVAIL OVER ANY CONFLICTING PROVISION WITHIN ANY STANDARD FORM CONTRACT OF THE BIDDER REGARDLESS OF ANY LANGUAGE IN BIDDER'S CONTRACT TO THE CONTRARY.

#### 1.1 **CLARIFICATION/EXPLANATION/QUESTIONS:**

Any questions concerning the Bid Specifications or any required need for clarification must be addressed to Purchasing at [Purchasing@sibfl.net](mailto:Purchasing@sibfl.net) by the date mentioned above. Interpretations or clarifications considered necessary by the City will be issued by addenda and posted/disseminated by DemandStar ([www.demandstar.com](http://www.demandstar.com)) to all parties listed on the official plan holders' list as having received the Bid documents. Only questions answered by written addenda shall be binding. Oral interpretations or clarifications shall be without legal effect. No plea of ignorance or delay or required need of additional information shall exempt a Proposers from submitting their Bid on the required date and time as publicly noted.

#### 1.2 **PLAN HOLDER'S LIST:**

As a convenience to vendors, the City of Sunny Isles Beach has made available via internet lists of all plan holders for each REQUEST FOR PROPOSALS, INVITATION TO BID, and request for qualifications. The information is available on-line at [www.demandstar.com](http://www.demandstar.com) or by calling the Office of the City Clerk at (305) 792-1703.

#### 1.3 **ADDENDA TO SPECIFICATIONS:**

If any addenda are issued after the initial specifications are released, the City will post and disseminate the addenda through DemandStar. For those projects with separate plans, blue prints, or other materials that cannot be accessed through the internet, the Office of the City Clerk will make good faith effort to ensure that all registered proposers (those who have been registered as receiving a Bid package) receive the documents. It is the responsibility of the vendor prior to the submission of any Bid to check the above website or contact the Office of the City Clerk at (305) 792-1703 to verify any addenda issued. The receipt of all addenda must be acknowledged on the Bid Response Sheet.

#### 1.4 **SPECIAL ACCOMMODATIONS:**

Any person requiring a special accommodation at a Pre-Bid Conference or Bid/RFP/RFQ opening because of a disability should call the Office of the City Clerk at (305) 792-1703 at least five (5) days prior to the Pre-Bid Conference or Bid/RFP/RFQ opening. If you are hearing or speech impaired, please contact the Office of the City Clerk by calling the City of Sunny Isles Beach using the Florida Relay Service which can be reached at 1(800) 955-8771 (TDD).

#### 1.5 **PUBLIC ENTITY CRIMES STATEMENT:**

Pursuant to the provisions of paragraph (2) (a) of section 287.133, Florida statutes -"a person or affiliate who has been placed on the convicted vendor list following a conviction for a public entity crime may not submit a Bid on a contract to provide any goods or services to a public entity, may not submit a Bid on a contract with a public entity for the construction or repair of a public building or public work, may not submit Bids on leases of real property to a public entity, may not be awarded to perform work as a Contractor, supplier, sub-Contractor, or consultant under a contract with any public entity, and may not transact business with any public entity in

excess of the threshold amount provided in section 287.107, for category two for a period of 36 months from the date of being placed on the convicted vendor list".

#### 1.6 **BID DEADLINE:**

Bids must be submitted no later than the time and date shown within this document.

#### 1.7 **SEALED BID:**

The entire Bid Response Package shall be placed in an opaque envelope (with all items listed on the Bid checklist form and all other items required within this INVITATION TO BID must be executed) and submitted in a sealed envelope.

#### 1.8 **BID EXECUTION, SIGNATURES, ERASURE/CORRECTION:**

All Bids shall be signed in blue ink. All price quotes shall be typewritten or printed with ink. All corrections made by the proposers prior to the opening must be initialed and dated by the proposers. No changes or corrections will be allowed after Bids are opened. Bids must contain an original, manual signature of an authorized representative of the company.

#### 1.9 **WITHDRAWAL OF BIDS:**

Proposers may withdraw Bids only by written request and shall forward the withdrawal request via "Certified U.S. Mail – Return Receipt Requested" prior to the Bid opening time. Negligence on the part of the Proposers in preparing the Bid confers no right for the withdrawal of the Bid after it has been opened.

#### 1.10 **BID OPENING:**

Bids will be opened publicly at the time and place stated in the Notice to Bidder. It is the responsibility of the proposers to insure that the Bid reaches the Office of the City Clerk on or before the closing hour and date stated on the INVITATION TO BID. After the Bid opening, the contents of the Bid Form will be made public for the information of vendors and other interested parties who may be present either in person or by representative. Bids that are received after the Bid opening time will not be considered and will not be returned.

#### 1.11 **EVALUATION OF BIDS:**

The City, at its sole discretion, reserves the right to inspect any/all Proposers facilities to determine their capability of meeting the requirements for the Contract. Also, price, responsibility, and responsiveness of the Proposers, the financial position, experience, staffing, equipment, materials, references, and past history of service to the City and/or with other units of state, and/or local governments in Florida, or comparable private entities, will be taken into consideration in the Award of the Contract.

1.11.1 Hold Harmless: All Proposer's shall hold the City, it's officials and employees harmless and covenant not to sue the City, it's officials and employees in reference to their decisions to reject, award, or not award a Bid, as applicable.

1.11.2 Cancellation: Failure on the part of the Proposers to comply with the conditions, specifications,



requirements, and terms as determined by the City, shall be just cause for cancellation of the Award.

1.11.3 Disputes: If any dispute concerning a question of fact arises under the Contract, other than termination for default or convenience, the Contractor and the City department responsible for the administration of the Contract shall make a good faith effort to resolve the dispute. If the dispute cannot be resolved by agreement, then the department with the advice of the City Attorney shall resolve the dispute and send a written copy of its decision to the Contractor, which shall be binding on both parties.

**1.12 AGREEMENT:**

After the Bid award, the City will, at its option, prepare an Agreement specifying the terms and conditions resulting from the award of this Bid. The vendor will have ten (10) calendar days after notification of the award by the City to execute the Agreement and provide the required Performance Bond.

The performance of the City of Sunny Isles Beach of any of its obligations under the agreement shall be subject to and contingent upon the availability of funds lawfully expendable for the purposes of the agreement for the current and any future periods provided for within the Bid specifications.

**1.13 PAYMENTS:**

Payment will be made after commodities/services have been received, accepted, and properly invoiced as indicated in the contract and/or purchase order. Invoices must bear the purchase order number.

**1.14 BRAND NAMES:**

If a brand name, make, of any "or equal" manufacturer trade name, or vendor catalog is mentioned whether or not followed by the words "approved equal" it is for the purpose of establishing a grade or quality of material only. Vendor may offer equals with appropriate identification, samples, and/or specifications on such item(s). The City shall be the sole judge concerning the merits of items Bid as equals.

**1.15 MATERIAL:**

Material(s) delivered to the City under this Bid shall remain the property of the seller until accepted to the satisfaction of the City. In the event materials supplied to City are found to be defective or do not conform to specifications, the City reserves the right to return the product(s) to the seller at the seller's expense.

**1.16 SAMPLES:**

Samples of items, when required, must be furnished by the Proposers free of charge to the City. Each individual sample must be labeled with the Proposers name and manufacturer's brand name and delivered by them within ten (10) calendar days of Proposers receipt of the "Notice to Proceed", unless schedule indicates a different time. If samples are requested subsequent to the Bid opening, they should be delivered within ten (10) calendar days of the request. The City will not be responsible for returning samples.

**1.17 QUANTITY GUARANTY:**

No guaranty or warranty is given or implied by the City as to the total amount that may or may not be purchased from any resulting Contract or Award. These quantities are for Bid purposes only and will be used for tabulation and presentation of the Bid. The City reserves the right to increase or decrease quantities as required, even significantly. The prices offered herein and the percentage rate of discount applies to other representative items not listed in this Bid.

**1.18 GOVERNMENTAL RESTRICTIONS ON MATERIALS:**

In the event any governmental restrictions may be imposed which would necessitate alteration of the material quality, workmanship, or performance of the items offered on this Bid prior to their delivery,

it shall be the responsibility of the successful Proposers to notify the City at once, indicating in their letter the specific regulation which required an alteration. The City of Sunny Isles Beach reserves the right to accept any such alteration, including any price adjustments occasioned thereby, or to cancel at no further expense to the City.

**1.19 SAFETY STANDARDS:**

The Proposers warrants that the product(s) supplied to the City conforms in all respects to the standards set forth in the occupational safety and health act (OSHA) and its amendments. Bids must be accompanied by a materials data safety sheet (MSDS) when applicable. Contractor shall take all necessary precautions for the safety of employees, and shall erect and properly maintain at all times all necessary safeguards for the protection of the employees and the public. Contractor shall follow all OSHA Safety Standards. Danger signs warning against hazards created by his/ her operation and work in progress must be posted.

All employees of the contractor shall be expected to wear safety glasses or goggles, appropriate clothing, and hearing protection when and wherever applicable. The contractor shall use only equipment that is fully operational and in safe operating order. Contractor shall be especially careful when servicing property when pedestrians and/ or vehicles are in close proximity — work shall cease until it is safe to proceed.

**1.20 WARRANTIES:**

Successful Proposers shall act as agent for the City in the follow-up and compliance of all items under Warranty/Guaranty and complete all forms for Warranty/Guarantee coverage under this Contract.

**1.21 COPYRIGHTS/PATENT RIGHTS:**

Proposers warrants that there has been no violation of copyrights or patent rights in manufacturing, producing or selling of goods shipped or ordered, as a result of this Bid. The seller agrees to indemnify City from any and all liability, loss, or expense occasioned by any such violation.

**1.22 LOCAL BUSINESS TAX (OCCUPATIONAL LICENSE REGISTRATION):**

The contractor shall be responsible for obtaining and maintaining throughout the contract period his or her city and county local business tax receipts. Each vendor submitting a Bid on this INVITATION TO BID shall include a copy of the company's local business tax/occupational license(s) with the Bid response. For information specific to City of Sunny Isles Beach local business tax/occupational licenses, please call Code Enforcement & Licensing at (305) 792-1705. If the contractor is operating under a fictitious name as defined in Section 865.059, Florida Statutes, proof of current registration with the Florida Secretary of State shall be submitted with the Bid. A business formed by an attorney actively licensed to practice law in this state, by a person actively licensed by the Department of Business and Professional Regulations or the Department of Health for the purpose of practicing his or her licensed profession, or by any corporation, partnership, or other commercial entity that is actively organized or registered with the Department of State shall submit a copy of the current licensing from the appropriate agency and/or proof of current active status with the Division of Corporations of the State of Florida.

**1.23 LIABILITY, INSURANCE, PERMITS AND LICENSES:**

Proposers shall assume the full duty, obligation, and expense of obtaining all necessary licenses, permits, inspections, and insurance required. The Proposers shall be liable for any damages or loss to the City occasioned by negligence of the Proposers (or their agent) or any person the Proposers has designated in the completion of their contract as a result of the Bid. Contractor shall be required to furnish a copy of all licenses, certificates of competency or other licenser requirements necessary to practice their profession as required by Florida State Statute, Miami-Dade County, and City of Sunny Isles Beach Code. Contractors shall include current Miami-Dade County Certificates of Competency. These documents shall be



furnished to the City along with the Bid response. Failure to furnish these documents or to have required licenser will be grounds for rejecting the Bid.

**1.24** **CERTIFICATE(S) OF INSURANCE:**

Proposers shall furnish to the Office of the City Clerk, City of Sunny Isles Beach, 18070 Collins Avenue, Sunny Isles Beach, Florida 33160, certificate(s) of insurance which indicate that insurance coverage has been obtained from an insurance company authorized to do business in the State of Florida or otherwise secured in a manner satisfactory to the City, for those coverage types and amounts listed in this document, in an amount equal to 100% of the requirements and shall be presented to the City prior to issuance of any Contract(s) or Award(s) Document(s). The City of Sunny Isles Beach shall be named as "additional insured" with respect to this coverage. The required certificates of insurance shall not only name the types of policies provided, but shall also refer specifically to this Bid and section. At the time of Bid submission the Proposers must submit certificates of insurance as outlined in the General Conditions section. All required insurances shall name the City of Sunny Isles Beach as additional insured and such insurance shall be issued by companies authorized to issue insurance in the State of Florida. It shall be the responsibility of the Proposers and insurer to notify the City Manager of the City of Sunny Isles Beach of cancellation, lapse, or material modification of any insurance policies insuring the Proposers, which relate to the activities of such vendor and the City of Sunny Isles Beach. Such notification shall be in writing, and shall be submitted to the City finance support service director thirty (30) days prior to cancellation of such policies. This requirement shall be reflected on the certificate of insurance. Failure to fully and satisfactorily comply with the city's insurance and bonding requirements set forth herein will authorize the City Manager to implement a rescission of the Bid award without further City Commission action. The Proposers hereby holds the City harmless and agrees to indemnify City and covenants not to sue the City by virtue of such rescission.

**1.25** **ASSIGNMENT:**

The Contractor shall not transfer or assign the performance required by this Bid without prior written consent of the City Manager. Any award issued pursuant to the INVITATION TO BID and monies which may be due hereunder are not assignable except with prior written approval of the City Manager. Further, in the event that the majority ownership or control of the Contractor changes hands subsequent to the award of this contract, Contractor shall promptly notify City in writing (via United States Postal Service – Certified Mail, Return Receipt Requested) of such change in ownership or control at least thirty (30) days prior to such change and City shall have the right to terminate the contract upon sixty (60) days written notice, at City's sole discretion.

**1.26** **HOLD HARMLESS/INDEMNIFICATION:**

The Contractor shall indemnify, hold harmless, and defend the City of Sunny Isles Beach, it's officers, agents and employees from and against any claims, demands or causes of action of whatsoever kind or nature arising out of error, omission, negligent act, conduct, or misconduct of the Contractor, their agents, servants or employees in the provision of goods or the performance of services pursuant to this Bid and / or from any procurement decision of the City including without limitation, awarding the Contract to the Contractor.

**1.27** **NON-CONFORMANCE TO CONTRACT:**

The City of Sunny Isles Beach may withhold acceptance of, or reject items which are found upon examination, not to meet the specification requirements. Upon written notification of rejection, items shall be removed within five (5) calendar days by the vendor at their own expense and redelivered at their expense. Rejected goods left longer than thirty (30) calendar days will be regarded as abandoned and the City shall have the right to dispose of them as its own property. Rejection for non-conformance or failure to meet delivery schedules may result in the Contractor being found in default.

**1.28** **DEFAULT PROVISION:**

In case of default by the Proposers, the City of Sunny Isles Beach may procure the articles or services from other sources and hold the Proposers responsible for any excess costs occasioned or incurred thereby.

**1.29** **SECONDARY/OTHER VENDORS:**

The City reserves the right in the event the primary vendor cannot provide an item(s) or service(s) in a timely manner as requested, to seek other sources without violating the intent of the Contract.

**1.30** **DEFINITIONS:**

Wherever used in these General Conditions or in the other Contract Documents, the following terms shall have the meaning indicated which shall be applicable to both the singular and plural thereof:

**Acceptance:** Acceptance by the City of the Work as being fully complete in accordance with the Contract Documents subject to waiver of claims.

**Agreement:** The written Agreement between the City and the Contractor covering the Work to be performed, which includes the Contract Documents.

**Addenda:** Written or graphic instruments issued prior to the Bid Opening which modify or interpret the Contract Documents, Drawings and Specifications, by addition, deletions, clarifications or corrections.

**Approved:** Means approved by the City.

**Bid or Proposal:** The offer of the Bidders/Proposers submitted on the prescribed form setting forth the prices for the Work to be performed.

**Proposers or Bidders:** Any person, firm or corporation submitting a Bid for Work.

**Bonds:** Bid, performance bond and other instruments of security, furnished by the Contractor and their surety in accordance with the Contract Documents and in accordance with the law of the State of Florida.

**Change Order:** A written order to the Contractor signed by the City authorizing an addition, deletion or revision in the Work, or an adjustment in the Contract Price or the Contract Time issued after execution of the Agreement.

**City:** City of Sunny Isles Beach, 18070 Collins Avenue, Sunny Isles Beach, Florida 33160.

**Contract Documents:** Contract Documents shall include, Instructions to Proposers, Contractor's Bid, the Bonds, the Notice of Award, the Agreement between the City and Contractor as well as any addenda thereto, these General Conditions, Special Conditions, the Technical Specifications, Drawings and Modifications, Notice to Proceed, Invitation to Bid, Insurance Certificates, Change Orders and Acknowledgment of Conformance with the City of Sunny Isles Beach.



**Contract Price:** The total monies payable to the Contractor under the Contract Documents.

**Contract Time:** The number of calendar days stated in the Agreement for the completion of the Work.

**Contracting Officer:** The individual who is authorized to sign the contract documents on behalf of the City's governing body.

**Contractor:** The person, firm or corporation with whom the City has executed this Agreement.

**Day:** A calendar day of twenty-four hours measured from midnight to the next midnight.

**Field Order:** A written order issued by the City which clarifies or interprets the Contract Documents or orders minor changes in the Work.

**Modification:** Modification means any one of the following: (a) a written amendment of the Contract Documents signed by both parties, (b) a Change Order, (c) a written clarification or interpretation if issued by the City, or (d) a written order for minor change or alteration in the Work issued by the City. A modification may only be issued after execution of the Agreement.

**Notice of Award:** The written notice by City to the apparent successful Proposers stating that upon compliance with the conditions precedent to be fulfilled by him within the time specified, City will execute and deliver the Agreement to him.

**Samples:** Physical examples which illustrate materials, equipment or workmanship and establish standards by which the Work will be judged.

**Specifications:** Those portions of the Contract Documents consisting of written technical descriptions of materials, equipment, construction systems, standards and workmanship as applied to the Work.

**Statement of Services:** The form furnished by the City which is to be used by the Contractor in requesting progress payments.

**Supplier:** Any person or organization who supplies materials or equipment for the Work, including that fabricated to a special design, but who does not perform labor at the site.

**Work:** Any and all obligations, duties and responsibilities necessary to the successful completion of the Project assigned to or undertaken by Contractor under the Contract Documents, including all labor, materials, equipment and other incidentals, and the furnishing thereof.

**Written Notice:** The term "Notice" as used herein shall mean and include all written notices, demands, instructions, claims, approvals and disapproval's required to obtain compliance with Contract requirements.

Written notice shall be deemed to have been duly served if delivered in person to the individual or to a member of the firm or to an officer of the corporation for whom it is intended, or to an authorized representative or such individual, firm, or corporation, or if delivered at or sent by registered mail to the last business address known to them who gives the notice. Unless otherwise stated in writing, any notice to or demand upon the City under this Contract shall be delivered to the City.

**1.31 BID AWARD:**

The City reserves the right to reject any and all Bids at its sole discretion. Bids shall be awarded by the City after the City performs all necessary searches, inquiries, exploration, and analysis of the Bids. The ITB shall be awarded to the lowest responsible and responsive Bidder whose Bid best serves the interests of and represents the best value to the City. No Notice of Award will be given until the City has concluded any investigation(s) as they deem necessary to establish the Proposer's capability to perform the Services as described in this RFP, ITB, RFQ or ITQ, as substantiated by the required professional experience, client references, technical knowledge and qualifications; and sufficient labor and equipment to comply with the City's established standards, as well as the financial capability of the Proposer to perform the Work in accordance with the Contract Documents to the satisfaction of the City within the time prescribed. The City reserves the right to reject the Bid of any Proposers on the basis of these queries and investigations and who does not meet the City's satisfaction, even though the firm may be the lowest dollars and cents Bid. In analyzing Bids, the City will also take into consideration client references, past work experience and work product, proven ability to satisfactorily perform. If the Contract is awarded, the City will issue the Notice of Award and give the successful Proposers a Contract for execution within ninety (90) days after opening of Bids. The City specifically reserves the right to award the contract to a proposer who is not necessarily the lowest dollars and cents proposers on the basis of the results of these queries and investigation(s).

**1.32 EXECUTION OF AGREEMENT:**

At least four counterparts of the Agreement, the Performance Bond, the Certificates of Insurance and such other Documents as required by the Contract Documents shall be executed and delivered by Contractor to the City within ten (10) calendar days of receipt of the Notice of Award.

**1.33 LAWS AND REGULATIONS:**

The Contractor will give all notices and comply with all laws, ordinances, rules and regulations applicable to the Work. If the Contractor observes that the Specifications are at variance therewith, they will give the City prompt written notice thereof, and any necessary changes shall be adjusted by an appropriate modification. If the Contractor performs any Work knowing it to be contrary to such laws, ordinances, rules and regulations, and without such notice to the City, they will bear all costs arising wherefrom.

**1.34 TAXES:**

The City of Sunny Isles Beach is exempt from sales tax imposed by the State and/or Federal Government. Florida Sales Tax Exemption No. 23-00-477131-54C appears on each purchase order. Exemption certificates are available upon request.

**1.35 DUTY TO DEFEND, INDEMNIFY AND SAVE HARMLESS:**

In consideration of the separate sum of twenty-five dollars (\$25.00) and other valuable consideration, the Contractor shall defend, indemnify and hold harmless the City, its officers, agents and employees, from or on account of any injuries or damages, received or sustained by any person or persons during or on account of any operations connected with the Work described in the Contract



Documents, or by or in consequence of any negligence in connection with the same; or by use of any improper materials or by or on account of any act or omission of the said Contractor or his Sub-Contractor, agents, servants or employees. The Contractor will defend, indemnify and hold harmless the City and their agents or employees from and against all claims, damages, losses and expenses including attorneys' fees arising out of or resulting from the performance of the Work, provided that any such claim damage, loss or expense (a) is attributable to bodily injury, sickness, disease or death, or to injury to or destruction of tangible property (other than Work itself) including the loss of use resulting wherefrom and (b) is caused in whole or in part by any negligent act or omission of the Contractor, Sub-Contractor, anyone directly or indirectly employed by any of them or anyone for whose acts any of them may be liable, regardless of whether or not it is caused by a party indemnified hereunder. In the event that a court of competent jurisdiction determines that Sec. 725.06 (2), F.S. is applicable to this Work, then in lieu of the above provisions of this section the parties agree that Contractor shall indemnify, defend and hold harmless the City, their officers and employees, to the fullest extent authorized by Sec. 725.06 (2) F.S., which statutory provisions shall be deemed to be incorporated herein by reference as if fully set forth herein. In the event that any action or proceeding is brought against City by reason of any such claim or demand, Contractor, upon written notice from City shall defend such action or proceeding by counsel satisfactory to City. The indemnification provided above shall obligate Contractor to defend at its own expense or to provide for such defense, at City's option, any and all claims of liability and all suits and actions of every name and description that may be brought against City, excluding only those which allege that the injuries arose out of the sole negligence of City, which may result from the operations and activities under this Contract whether the Work be performed by Contractor, its Sub-Contractors, or by anyone directly or indirectly employed by either.

**1.36 DECISIONS ON DISAGREEMENTS:**

The City will be the initial interpreter of the Technical Specifications.

**1.37 CITY MAY TERMINATE:**

If the Contractor is adjudged bankrupt or insolvent, or if they make a general assignment for the benefit of their creditors, or if a trustee or receiver is appointed for the Contractor or for any of their property, or if they file a petition to take advantage of any debtor's act, or to reorganize under bankruptcy or similar laws, or if they repeatedly fails to supply sufficient skilled workmen or suitable materials or equipment, or if they repeatedly fail to make prompt payments to Sub-Contractors or for labor, materials or equipment or they disregard laws, ordinances, rules, regulations or orders of any public body having jurisdiction, or if they disregard the authority of the City, or if they otherwise violate any provision of, the Contract Documents, then the City may, without prejudice to any other right or remedy and after giving the Contractor and the surety ten (10) days written notice, terminate the services of the Contractor and take possession of the Project and of all materials, equipment, tools, construction equipment and machinery thereon owned by the Contractor, and finish the Work by whatever method they may deem expedient. In such case the Contractor shall not be entitled to receive any further payment until the Work is finished. If the unpaid balance of the Contract Price exceeds the direct and indirect costs of completing the Project, including compensation for additional professional services, such excess shall be paid to the Contractor. If such costs exceed such unpaid balance, the Contractor will pay the difference to the City. Such costs incurred by the City will be determined by the City and incorporated in a Change Order. If after termination of the Contractor under this Section, it is determined by a court of competent jurisdiction for any reason that the Contractor was not in default, the rights and obligations of the City and the Contractor shall be the same as if the termination had been issued pursuant to this document.

1.37.1 Where the Contractor's services have been so terminated by the City said termination shall not affect any rights of the City against the Contractor then existing or which may thereafter accrue. Any retention

or payment of moneys by the City due the Contractor will not release the Contractor from liability.

1.37.2 Upon ten (10) days written notice to the Contractor, the City may, without cause (termination for convenience) and without prejudice to any other right or remedy, elect to terminate the Agreement. In such case, the Contractor shall be paid for all Work executed and accepted by the City as of the date of the termination. No payment shall be made for profit for Work which has not been performed.

**1.38 MISCELLANEOUS:**

Proposers acknowledge the following miscellaneous conditions:

**1.38.1** Whenever any provision of the Contract Documents requires the giving of written notice it shall be deemed to have been validly given if delivered in person to the individual or to a member of the firm or to an officer of the corporation for whom it is intended, or if delivered at or sent by registered or certified mail, postage prepaid, to the last business address known to them who gives the notice.

**1.38.2** The Contract Documents shall remain the property of the City. The Contractor shall have the right to keep one record set of the Contract Documents upon completion of the Project.

**1.38.3** The duties and obligations imposed by these General Conditions, Special Conditions and Supplemental Conditions and the rights and remedies available hereunder, and, in particular but without limitation, the warranties, guarantees and obligations imposed upon Contractor and those in the Special Conditions and the rights and remedies available to the City, shall be in addition to, and shall not be construed in any way as a limitation of, any rights and remedies available by law, by special guarantee or by other provisions of the Contract Documents.

**1.38.4** Should the City or the Contractor suffer injury or damage to its person or property because of any error, omission, or act of the other or of any of their employees or agents or others for whose acts they are legally liable, claim shall be made in writing to the other party within a reasonable time of the first observance of such injury or damage.

**1.39 WAIVER OF JURY TRIAL:**

City and Contractor knowingly, irrevocably voluntarily and intentionally waive any right either may have to a trial by jury in State or Federal Court proceedings in respect to any action, proceeding, lawsuit or counterclaim based upon the Contract Documents or the performance of the Work there under.

**1.40 GOVERNING LAW:**

The Contract shall be construed in accordance with and governed by the law of the State of Florida.

**1.41 VENUE:**

Venue of any action to enforce the Contract Documents shall be in Miami-Dade County, Florida.

**1.42 ARBITRATION:**

It is the intention of the parties that whenever possible, if a dispute or controversy arises hereunder then such dispute or controversy shall be settled by arbitration in accordance with the procedures, rules and regulations of the American Arbitration Association. The decision rendered by the Arbitrator shall be final and binding upon the parties and judgment upon the award rendered by the arbitrator





may be entered in any court having jurisdiction. Arbitration shall be held in Miami-Dade County, Florida. All costs of arbitration and attorneys' fees incurred by the parties shall be paid by the non-prevailing party or, if neither party prevails on the whole, each party shall be responsible for a portion of the costs of arbitration and their respective attorneys' fees as may be determined by the court on confirmation.

**1.43** **PROJECT RECORDS:**

City shall have right to inspect and copy during regular business hours at City's expense, the books and records and accounts of Contractor which relate in any way to the Project, and to any claim for additional compensation made by Contractor, and to conduct an audit of the financial and accounting records of Contractor which relate to the Project. Contractor shall retain and make available to City all such books and records and accounts, financial or otherwise, which relate to the Project and to any claim for a period of three years following final completion of the Project. During the Project and the three year period following final completion of the Project, Contractor shall provide City access to its books and records upon five days written notice.

**1.44** **SEVERABILITY:**

If any provision of the Contract or the application thereof to any person or situation shall to any extent, be held invalid or unenforceable, the remainder of the Contract, and the application of such provisions to persons or situations other than those as to which it shall have been held invalid or unenforceable shall not be affected thereby, and shall continue in full force and effect, and be enforced to the fullest extent permitted by law.

**1.45** **INDEPENDENT CONTRACTOR:**

The Contractor is an independent Contractor under the Contract. Services provided by the Contractor shall be by employees of the

Contractor and subject to supervision by the Contractor, and not as officers, employees, or agents of the City. Personnel policies, tax responsibilities, social security and health insurance, employee benefits, purchasing policies and other similar administrative procedures, applicable to services rendered under the Contract shall be those of the Contractor.

**1.46** **PROHIBITION AGAINST CONTRACTING WITH SCRUTINIZED COMPANIES:**

Pursuant to Florida Statutes Section 217.4725, contracting with any entity that is listed on the Scrutinized Companies that Boycott Israel List or that is engaged in the boycott of Israel is prohibited. Contractors must certify that the company is not participating in a boycott of Israel. Any contract for goods or services of One Million Dollars (\$1,000,000) or more shall be terminated at the City's option if it is discovered that the entity submitted false documents of certification, is listed on the Scrutinized Companies with Activities in Sudan List, the Scrutinized Companies with Activities in the Iran Petroleum Energy Sector List, or has been engaged in business operations in Cuba or Syria after July 1, 2018. Any contract entered into or renewed after July 1, 2018 shall be terminated at the City's option if the company is listed on the Scrutinized Companies that Boycott Israel List or engaged in the boycott of Israel.

Contractors must submit the certification that is attached to this agreement. Submitting a false certification shall be deemed a material breach of contract. The City shall provide notice, in writing, to the Contractor of the City's determination concerning the false certification. The Contractor shall have ninety (90) days following receipt of the notice to respond in writing and demonstrate that the determination was in error. If the Contractor does not demonstrate that the City's determination of false certification was made in error, then the City shall have the right to terminate the contract and seek civil remedies pursuant to Florida Statute Section 215.4725.

**End of Section**



## Section 2 Special Terms and Conditions

### 2.1 PURPOSE OF THE ITB

The City of Sunny Isles Beach (the "City"), a municipality located in Miami-Dade County, Florida, is requesting bids from qualified Contractors ("Proposers", "Bidders", "Contractors" or "Firms") to reconstruct the east end of 172nd Street to raise the road and eliminate flooding at high tide, as described in Attachment A. The Contractor shall furnish all labor, equipment and materials necessary to construct the improvements to the roadway system in accordance with the specifications herein and the resulting Contract Documents. Bidder shall warranty all labor completed for 365 days from final acceptance.

The City seeks to award a contract and commence construction no earlier than the first week of June 2023, which construction shall be completed no later than August 11, 2023.

The budget for this project is \$420,000.00.

Ross Engineering, Inc., the City's Consulting Engineer ("City Engineer"), shall serve as agent for the City in all matters pertaining to the work on this project. No changes in the work or extra charges to the Contract are effective until recommended by the City Engineer and approved by the City in the form of a written change order. The City Engineer is precluded from bidding on this Project due to their involvement in the creation of the scope of work.

### 2.2 MINIMUM QUALIFICATION REQUIREMENTS (MQRs)

- a. The **Prime Contractor** shall hold the proper license in the State of Florida to perform the Scope of Work set forth within this solicitation to include being registered as a **Certified General Contractor with the State of Florida** along with registration to conduct business in the State of Florida in all required disciplines. Proposing Firm must provide a copy of the applicable license(s) with Firm's response.
- b. The **Proposing bidder** must have been awarded **Prime Contractor** and successfully performed **three (3) roadway/drainage improvement projects** of similar or greater size, scope and complexity to the specifications of the ITB within the last **five (5) years**.
- c. Bidder shall provide **reference letters** for **no less than three (3) projects** in which Contractor served as **Prime Contractor** for projects similar in size and scope. Please note that the references must be for the same projects in response to MQR "b" above.
- d. Provide documentation of **bidder's total and single project bonding capacity** and the



name and current financial rating (A.M. Best) of the surety company utilized by your Firm. Provide documentation of your firm's total and single project bonding capacity and the name and current financial rating (A.M. Best) of the surety company utilized by your firm. Bidders shall have a single project bonding capability of at least Five Hundred Thousand (\$500,000.00) with a surety company with an A.M. Best rating of AA or better.

### 2.3 **NON-MANDATORY PRE-BID MEETING**

A non-mandatory pre-bid conference will be held on **MONDAY, MARCH 13, 2023 AT 11:00 AM** at Sunny Isles Beach Government Center located at 18070 Collins Avenue Sunny Isles Beach, FL 33160, First Floor Conference Room, to discuss the special conditions and specifications included within this solicitation. Proposers are requested to bring this solicitation document to the conference, as additional copies may not be available. It is strongly encouraged that Firms interested in proposing to this ITB attend the Pre-Bid Meeting as a tool to be successful in responding to the City's project.

### 2.4 **EXAMINATION OF SITE**

Each bidder shall visit the site of the proposed work before submitting a bid and shall fully familiarize themselves with conditions relating to construction and labor so that he or she may fully understand the facilities, difficulties and restrictions attending the execution of work under the Contract. It will be assumed that the Bidder has investigated and is satisfied as to the conditions of work to be performed and materials to be furnished and shall base Bid on their own opinion of the conditions likely to be encountered, and for the bid price must assume all risk of variance, by whomsoever made in any computation or statement of amounts or quantities necessary to fully complete the work in strict compliance with the Contract Documents.

### 2.5 **TERM**

The resultant contract will commence upon execution by both parties which shall be the effective date succeeding approval of the contract by the City Commission. Prior to initiating the performance of any services under this Agreement, Contractor must receive a written Notice to Proceed from the City Manager and/or the City Engineer. Bid award is anticipated for April 20, 2023 with a Notice to Proceed issued by May 1, 2023. Although materials may be ordered and stored near the site, the project schedule of physical work on-site that requires lane closures shall only occur between June 1, 2023 and August 11, 2023 providing for 72 days of roadwork. The project shall be substantially completed within **fifty-two (52) calendar days from the Project initiation specified in the Notice to Proceed and final completion within seventy-two (72) calendar days** from Project date specified in the Notice to Proceed. The total **seventy-two (72) calendar days** include weekend days and holidays.



Failure to complete all the work within the time specified above, including any extension granted in writing by the City, shall obligate the Contractor to pay the City, as **liquidated damages** and not as a penalty, an amount equal to **Five Hundred Dollars (\$500) for each calendar** day of delay in the completion of all the work. If any liquidated damages are unpaid by the Contractor, the City shall be entitled to deduct these unpaid liquidated damages from the monies due the Contractor.

## 2.6 **METHOD OF AWARD**

The term “lowest responsible and responsive Bidder” as used herein shall mean the Bidder whose bid is the lowest of those Bidders possessing the skill, ability and integrity necessary for the faithful performance of the work, whose bid best serves the interests of and represents the best value to the City, as determined by the City Commission and/or the City Manager. The bidder will also be evaluated as part of their “responsibleness” on their quality control plan, safety plan and proposed project schedule.

Firms will be evaluated by relevant experience, preferably with government agencies, successful past performance, no conflicts of interest, approach to the project and whose bid best serves the interest of and represents the best value to the City in conformity with the criteria set. The City Manager may also reject all proposals received. Section 62-8 of the City Code provides that the City may consider the following:

- The ability, capacity and skill of the vendor to perform the Contract.
- The character, integrity, reputation, judgment, experience and efficiency of the vendor.
- The quality of performance of previous contracts with the City and references.
- The previous and existing compliance by the vendor with laws and ordinances relating to the Contract.

The City also reserves the right to waive minor variations to specifications (interpretation of minor variations will be made by applicable City Procurement personnel). In addition, the City reserves the right to cancel any contract by giving thirty (30) days written notice. The City reserves the right to negotiate the type and cost of specific types of services to be purchased.

## 2.7 **SUB-CONTRACTORS**

If one or more subcontractors are to be used, the subcontractor must be clearly identified and noted in the submittal when it is submitted. The City must approve any changes in the use of subcontractors in advance and in writing. No such approval will be construed as making the City a party to such subcontract, or subjecting the City to liability of any kind to any subcontractor. No subcontractor will under any circumstances relieve the Proposer of its liability and obligation under any resulting contract. Subcontractor is subject to the same contractual conditions as is the Respondent.



The City/City's Representative shall promptly notify the Contractor, in writing, if either the City or Engineer, after due investigation, has reasonable objections to any subcontractor on said list and does not accept them. Failure of the City or Engineer to make objection to any subcontractor on the list shall constitute acceptance of such subcontractor. After acceptance, no subcontractor shall be changed without written approval by the City and Engineer.

## **2.8 FIRM BID PRICE**

If the Bidder is awarded a contract under this solicitation, the prices proposed by the Bidder shall remain fixed and firm during the term of the contract.

## **2.9 PERFORMANCE AND PAYMENT BOND**

The City of Sunny Isles Beach **shall** require the successful Bidder to furnish a Performance Bond and Payment Bond in the amount of 100% of the total Bid Price, with the City of Sunny Isles Beach as the Obligee, as security for the faithful performance of the Contract and for the payment of all persons performing labor or furnishing materials in connection herewith within ten (10) calendar days after issuance of the Notice of Award by the City. The Performance and Payment Bond shall continue in effect through the contract term. The bonds shall be with a surety company authorized to do business in the State of Florida and having been in business with a record of successful continuous operation for at least five (5) years.

The Performance Bond shall guarantee all work and materials furnished under the Contract including losses resulting from defects in the materials or improper performance of Work under the Contract that may appear or be discovered during performance of the Work or during any applicable warranty period after completion of all Work, and for latent defects, during the time period agreed upon.

### **BONDING CAPACITY LETTER:**

Provide documentation of bidder's total and single project bonding capacity and the name and current financial rating (A.M. Best) of the surety company utilized by your Firm.

## **2.10 DELIVERY & PROTECTION OF MATERIAL AND EQUIPMENT**

Requirements warrant that lead-times for furnishing and delivery of equipment and supplies will need to be considered to accommodate the project timeframe. Due to long fabrication and delivery lead times, Contractor shall provide to the City a list of equipment required to maintain orderly progress of the Work and those required to order immediately upon NTP.



All material must be F.O.B. destination City of Sunny Isles Beach. The Contractor is solely liable and responsible for the purchase, delivery, and installation of all materials and equipment. The contractor will make all arrangements in regards to delivery, storage, installation, and warranty requirements. Contractor will be solely liable for receiving, inspecting, accepting, and replacing any damaged materials or equipment and filing any and all claim with suppliers or transporters. Contractor is responsible for the protection of all materials and equipment from adverse weather conditions, damage, deterioration, and theft until the Work has been accepted by the City.

All bidders shall quote prices based on furnished and installed materials. Bidder shall hold title to the goods until such time as they are delivered to, and accepted by, an authorized City representative.

## **2.11 INSURANCE**

### **Comprehensive General Liability Insurance**

General Liability for Bodily Injury & Property Damage with limits of \$1,000,000 per occurrence and \$2,000,000 annual aggregate on a primary and non-contributory basis, including the City of Sunny Isles Beach as Additional Insured, with a Waiver of Subrogation to the City and a Hold Harmless Agreement. Coverage must be offered in a form no more restrictive than the latest edition of the Comprehensive General Liability policy, without restrictive endorsements, as filed by the Insurance Services Office, and shall specifically include the following with minimum limits not less than those required for Bodily Injury Liability and Property Damage Liability:

- Premises and Operation;
- Independent Contractors;
- Products and/or Completed Operations Hazard;
- Broad Form Property Damage;
  - Broad Form Contractual Coverage applicable to this specific Contract, including any hold harmless and/or indemnification agreement.
  - Personal Injury Coverage with Employee and Contractual Exclusions removed, with minimum limits of coverage equal to those required for Bodily Injury Liability and Property Damage Liability.
- \$3,000,000 Umbrella/Excess Liability over and above and following the above mentioned General Liability & Commercial Automobile Liabilities.

#### **2.11.2 Business Automobile Liability**

Business Automobile Liability with minimum limits of One Million Dollars (\$1,000,000.00) per occurrence combined single limit for Bodily Injury Liability and Property Damage Liability. Coverage must be afforded on a form no more restrictive than the latest edition



of the Business Automobile Liability policy, without restrictive endorsements, as filed by the Insurance Services Office, and must include:

- Owned Vehicles;
- Hired and Non-Owned Vehicles;
- Employers' Non-City ship.

Before starting the Work, the Bidder will file and make sure that all certificates of insurance required by this document and by the Contract are in the City's possession. These certificates shall contain a provision that the coverage afforded under the policies will not be canceled or materially changed until at least thirty (30) days prior written notice has been given to the City by certified mail. The City shall be named as an additional insured on the above-referenced policies.

The Bidder agrees that if any part of the Work under the Contract is sublet, they will require the Sub-Contractor(s) to carry insurance as required, and that they will require the Sub-Contractor(s) to furnish to them insurance certificates similar to those required by the City in this section.

### **2.11.3 Worker's Compensation Insurance**

Worker's Compensation Insurance for statutory obligations imposed by Worker's Compensation or Occupational Disease Laws, including, where applicable, the United States Longshoremen's and Harbor Worker's Act, the Federal Employers' Liability Act and the Homes Act. 4. Workers' Compensation in accordance with Florida Statute, including Employer's Liability of \$1,000,000. Bidder agrees to be responsible for the employment, conduct and control of its employees and for any injury sustained by such employees in the course of their employment

**2.11.4 Builder's Risk Insurance** – Coverage shall be "All Risk" coverage for one hundred percent (100%) of the completed value of the structure(s), building(s) or addition(s). Where contract calls for install of machinery or equipment, the policy must be endorsed to provide coverage on "All Risk" basis during transit and installation. The policy must be issued with a deductible of not more than \$50,000 per claim.

### **2.11.5. Cancellation and Re-Insurance**

It shall be the responsibility of the bidder and insurer to notify the City Manager of the City of Sunny Isles Beach of cancellation, lapse, or material modification of any insurance policies insuring the Proposers, which relate to the activities of such vendor and the City of Sunny Isles Beach. Such notification shall be in writing, and shall be submitted to the City finance support service director thirty (30) days prior to cancellation of such policies. This requirement shall be reflected on the certificate of insurance. Failure to fully and satisfactorily comply with the city's insurance and bonding requirements set forth herein will



authorize the City Manager to implement a rescission of the Bid award without further City Commission action.

**NOTE: THE CITY OF SUNNY ISLES BEACH, CONTRACT NUMBER AND TITLE MUST APPEAR ON EACH CERTIFICATE OF INSURANCE. THE CITY OF SUNNY ISLES BEACH MUST BE SHOWN AS AN ADDITIONAL INSURED WITH RESPECT TO THIS COVERAGE.**

## **2.12 PROGRESS PAYMENTS**

Progress payments shall be considered based upon the Contractor's Applications for Payment submitted to the Project Manager and upon Certificates for Payment subsequently issued to the Owner by the Project Manager. The Owner shall make progress payments to the Contractor on account of the Contract Price subject to the terms and conditions in the resultant Agreement.

Each invoice or payment application must be accompanied by all supporting documentation and other information reasonably requested by City, including, but not limited to a Partial Release of Lien or Final Release of Lien as appropriate in the forms set forth in Chapter 713.20, Florida Statutes. Reference herein to Chapter 713, Florida Statutes is for convenience, and shall not be construed as a waiver of sovereign immunity or authority for imposition of liens against public property. Each progress payment shall be reduced by five percent (5%) retainage. Subject to other requirements of the Contract Documents, retainage shall be released after final completion of the Work and City's receipt of acceptable reports and other documentation including certification of payment to subcontractors, if any, and a Final Release of Lien in the form set forth in Section 713.20, Florida Statutes.

Contractor is advised that processing of invoices must follow this schedule, as the City has funding requirements and other payment obligations which may prevent payment of late Statement of Services for that month's billing cycle.

## **2.13 COMPLIANCE WITH FEDERAL STANDARDS**

All items to be purchased under this contract shall be in accordance with all governmental standards, to include, but not be limited to, those issued by the Occupational Safety and Health Administration (OSHA), the National Institute of Occupational Safety Hazards (NIOSH), and the National Fire Protection Association (NFPA) and applicable provisions of the Americans with Disabilities Act (ADA) in the course of providing any services.

## **2.14 PERMITS**

The Contractor shall obtain and pay for all licenses, permits (please refer to permit fees [here](#)) and inspection fees required for this project; and shall comply with all laws, ordinances, regulations





and building code requirements applicable to the work contemplated herein. Damages, penalties and or fines imposed on the City or the Contractor for failure to obtain required licenses, permits or fines shall be borne by the Contractor. Contractor shall be required to furnish a certified copy of all licenses, certificates of competency or other licensure requirements necessary to practice his profession as required by Florida Statutes, Florida Building Code, Miami-Dade County, or City of Sunny Isles Beach Code. These documents shall be furnished to the City along with the Bid response. Failure to furnish these documents or to have required licensure will be grounds for rejecting the Bid as non-responsive or otherwise.

Contractor shall always have a copy of approved permit and associated plans on the jobsite. It is the Contractor's responsibility to coordinate notice of commencement, and coordinate with the permitting authority having jurisdiction on any requirements given as a conditional approval of the permitting.

Pursuant to Florida Statute Section 218.80, the City hereby discloses that the following licenses, permit and fees and their costs are issued by the City for construction. Licenses, permits and fees applicable to this Project are within the link found below and must be obtained and/or paid by the awarded Bidder. The successful Bidder is responsible to identify and obtain all applicable licenses, permit and pay all such related fees. The costs of all licenses permits and their respective fees applicable to this Project are to be secured and paid for by the awarded Bidder.

Click [here](#) to view the permit fee schedule.

## **2.15 LABOR, MATERIALS, AND EQUIPMENT SHALL BE SUPPLIED BY THE CONTRACTOR**

The Contractor shall furnish the following, including but not limited to, all labor, material, equipment, barricading, Maintenance of Traffic (MOT) inclusive of any required off duty police officers, adequate supervision, and coordination for satisfactory contract performance. When not specifically identified in the technical specifications, such materials and equipment shall be of a suitable type and grade for the purpose and meeting or exceeding all permit or industry standard requirements. All material, workmanship, 100% design, testing and equipment shall be subject to the inspection and approval of the City Manager or his designated representative for this project.

## **2.16 ACCIDENT PREVENTION AND BARRICADES**

Barricades, cones, construction fencing, temporary construction fencing and off duty police officers, per City regulations and other relevant requirements, shall be provided by the Contractor when work is performed in areas traversed by persons, vehicular traffic or when deemed necessary by the City Manager at no extra cost to the City. CONTINUOUS OFF-DUTY POLICE SUPPORT SHALL BE REQUIRED FOR ALL WORK RESULTING IN MODIFICATIONS TO THE EXISTING TRAFFIC FLOW PATTERNS INCLUDING BUT NOT LIMITED TO LANE CLOSURES AND DETOURS OR WHERE OTHERWISE REQUESTED BY THE CITY.



Contractor shall comply with City, State and Federal regulations and permit requirements for the placement of the proper Traffic Control Devices. Precautions shall be exercised at all times for the protection of persons and property. All services performed under this contract shall conform to all relevant regulations as prescribed in the current edition of the Manual of Uniform Traffic Control Devices (MUTCD), the Florida Department of Transportation's Design Standards (DS) and OSHA during the course of such effort. Where requirements vary or conflict, the more stringent shall apply. Any fines levied by the above mentioned authorities for failure to comply with these requirements shall be borne solely by the Contractor.

The Contractor is to maintain appropriate signage, guards, and flagmen for the purpose of safeguarding the general public while work is ongoing. All work shall be completed in a safe and workmanlike manner every day and the Contractor shall secure the site prior to leaving at the end of each and every day.

**2.17 CORRECTION OR REMOVAL OF DEFECTIVE WORK**

If required by City, Contractor shall promptly, as directed and at its sole expense, either correct all defective Work, whether or not fabricated, installed or completed, or, if the Work has been rejected by City, remove it from the site and replace it with non-defective Work. Contractor shall bear all direct, indirect and consequential costs of such correction or removal (including but not limited to fees and charges of engineers, architects, attorneys and other professionals) made necessary thereby.

**2.18 CHANGE ORDER**

The Contract may only be changed by a Change Order approved by the City. Any increase or decrease in the Contract Price or adjustment in the Contract Time shall be based on written notice by the Contractor delivered promptly to the City (but in no event later than seven (7) days) after the acknowledgement or occurrence of the event giving rise to the claim and stating the general nature of the claim. Within fourteen (14) days thereafter, notice of the amount of the claim with all supporting data shall cover all amounts (direct, indirect and consequential) to which the claimant is entitled as a result of the occurrence of said event. All claims for adjustment in the Contract Price or Contract Time shall be determined by the City.

The value of any Work covered by a Change Order or of any claim for an increase or decrease in the Contract Price or Contract Time shall be determined by: 1) mutual acceptance of a lump sum (which may include an allowance for overhead and profit) or 2) by application of unit prices contained in the Contract Documents to the quantities of the items involved. The City shall decide, in its sole discretion, whether to issue and agree to a Change Order, and verbal representations or instructions may not be relied upon by the Contractor.



## 2.19 DISCREPANCIES

Should a Bidder find discrepancies or ambiguities in, or omissions from, the Drawings or Specifications, or should they be in doubt as to their meaning, they shall at once notify the City in writing.

## 2.20 DAMAGE TO PUBLIC OR PRIVATE PROPERTY

If property (public or private) is damaged while contractor is performing work specified or is removed for the convenience of the work, it shall be repaired or replaced at the expense of the contractor in a manner acceptable to the City prior to the final acceptance of the work. Contractor will be responsible for applying and securing any permits that may be required to complete such repairs. Such property shall include but not be limited to: existing facilities and all of its components, site amenities, concrete and/or asphalt surfaces, vehicles, structures, sidewalks, curbs and gutters, driveways, utilities, etc. Contractor must provide protection necessary to prevent damage to property being repaired or replaced. If the work site has any pre-existing damage, the Contractor shall notify the Public Works/Capital Projects Department in writing. Failure to do so shall obligate the contractor to make repairs per the above section.

## 2.21 UTILITY

It shall be the responsibility of the Contractor to contact all affected utility owners and determine the precise locations of all utilities prior to beginning construction. **Utility owners shall be contacted a minimum of 72 hours prior to the commencement of operations.** Special care shall be used in working around or near existing utilities, protecting them when necessary to provide uninterrupted service. In the event that any utility service is interrupted, the Contractor shall notify the utility owner immediately and shall cooperate with the owner, or his representative, in the restoration of service in the shortest time possible. Existing fire hydrants shall be kept accessible to fire departments at all times.

## 2.22 FINAL CLEAN-UP

The Contractor shall at all times keep the premises free from accumulation of waste materials or rubbish caused by his employees or the Work. Upon final completion of the Work and before acceptance and final payment shall be made, the Contractor shall clean and remove from the site and adjacent property, all surplus and discarded materials, rubbish, and temporary structures. The Contractor shall restore in an acceptable manner all property which, has been damaged during the execution of the work. The Contractor shall leave the site and vicinity unobstructed in a neat and presentable condition throughout the entire area.

The contractor shall properly dispose, at its own cost, of any waste resulting from the work being performed in an approved facility at an approved site unless otherwise specified in this document.



### **2.23 E-VERIFY**

Florida Statute 448.095 directs all public employers, including municipal governments, to verify the employment eligibility of all new public employees through the U.S. Department of Homeland Security's E-Verify System, and further provides that a public employer may not enter into a contract unless each party to the contract registers with and uses the E-Verify system. Florida Statute 448.095 further provides that if a contractor enters into a contract with a subcontractor, the subcontractor must provide the contractor with an affidavit stating that the subcontractor does not employ, contract with, or subcontract with an unauthorized alien.

In accordance with Florida Statute 448.095, all contractors doing business with the City of Sunny Isles Beach are required to verify employee eligibility using the E-Verify system for all existing and new employees hired by the contractor during the contract term. Further, the contractor must also require and maintain the statutorily required affidavit of its subcontractors. It is the responsibility of the awarded vendor to ensure compliance with E-Verify requirements (as applicable). To enroll in E-Verify, employers should visit the E-Verify website (<https://www.e-verify.gov/employers/enrolling-in-e-verify>) and follow the instructions. The contractor must, as usual, retain the I-9 Forms for inspection.

### **2.24 VALUE ENGINEERING**

The City is open to any meaningful value engineering that would reduce the overall cost without compromising the integrity. Any innovative idea shall be included in the bid proposal.

### **2.25 HOURS OF CONSTRUCTION**

The Contractor shall minimize the impact of this project on the general public ensuring that all service interruptions are kept to a minimum and providing temporary services, structures, and facilities as required. The existing service to the residents and businesses may not be interrupted for more than 4 hours without written permission from the City. The Contractor shall perform work between the hours 7:00 AM and 7:00 PM Monday through Thursday and 7:00 AM – 5:00 PM on Fridays; and weekends with permission or as restricted by the local jurisdiction. Work outside these hours or on weekends and holidays is prohibited without permission from the City.

### **2.26 SHOP DRAWINGS**

The CONTRACTOR shall submit Shop Drawings for all fabricated structures, pipe asphalt mix. The purpose of the Shop Drawings is to show the suitability, efficiency, technique of manufacture, installation requirements, details of the item and evidence of its compliance or noncompliance with the Bid Project.

The CITY ENGINEER'S approval of the Shop Drawings will be general and shall not relieve the CONTRACTOR of responsibility for the accuracy of such Drawings, nor for the proper fitting and construction of the work,



nor for the furnishing of materials or work required by the Contract and not indicated on the Drawings. No work called for by Shop Drawings shall be performed until the said Drawings have been approved by the CITY ENGINEER. Approval shall not relieve the CONTRACTOR from responsibility for errors or omissions of any sort on the Shop Drawings.

The CONTRACTOR shall keep one set of Shop Drawings marked with the CITY ENGINEER'S approval at the job site at all times.

**2.27 WARRANTY**

The drainage system supplied and installed for this project shall be warranted to be free of defects for a period of one (1) year after completion of the project.

**2.28 PUBLIC RECORDS LAW**

The City is subject to Chapter 119, Florida Statutes, "Public Records Law." No claim of confidentiality or proprietary information in all or any portion of a response will be honored unless a specific exemption from the Public Law exists and is cited in the response. An incorrectly claimed exemption does not disqualify the firm, only the exemption claimed. Contractor acknowledges the public shall have access at all reasonable times, to all documents and information pertaining to City's contracts, subject to the provisions of Chapter 119, Florida Statutes, and agrees to allow access by the City and the public to all documents subject to disclosures under applicable law. To the extent that Contractor has been provided access to or has received security sensitive information, as defined by Florida Statutes, Section 119.071 and/or has executed a Confidential Information Acknowledgement and Agreement as part of the ITB process, Contractor shall keep and maintain the security sensitive information as confidential and exempt from public disclosures as required by Florida Statutes.

**IF THE CONTRACTOR HAS QUESTIONS REGARDING THE APPLICATION OF CHAPTER 119, FLORIDA STATUTES, TO THE SUCCESSFUL PROPOSER'S DUTY TO PROVIDE PUBLIC RECORDS RELATING TO THIS AGREEMENT, CONTACT THE CUSTODIAN OF PUBLIC RECORDS AT CITY OF SUNNY ISLES BEACH 18070 COLLINS AVENUE, SUNNY ISLES BEACH, FL 33160. THE CITY CLERK'S OFFICE MAY BE CONTACTED BY PHONE AT (305) 792-1703 OR VIA EMAIL AT MBetancur@sibfl.net.**

**END OF SECTION**



## SECTION 3

### SCOPE OF SERVICES / TECHNICAL SPECIFICATIONS

#### 3.0 **SCOPE OF SERVICE:**

The City of Sunny Isles Beach (the "City"), a municipality located in Miami-Dade County, Florida, is requesting bids from qualified Contractors ("Proposers", "Bidders", "Contractors" or "Firms") to reconstruct the east end of 172nd Street to raise the road and eliminate flooding at high tide, as described in Exhibit A.

Contractors will adhere to industry standard quality installation principles and provide quality installation services to ensure that the most reliable and cost-effective project is built. Contractors interested in performing these services must exhibit considerable relevant experience with this type of work, and should emphasize both experience and capability of particular personnel who will actually perform the work. Contractors should demonstrate that they have experience working with construction renovation, preferably for government.

#### 3.1 **AS-BUILT RECORDS:**

A complete set of as-built records shall be kept by the Contractor at the job site. These records shall show all items of construction and equipment which differ in size, shape or location from those shown on the Contract drawings, also any additional work, existing features or utilities revealed by construction work which are not shown on the Contract drawings. These records shall be kept up to date daily. They may be kept on a marked set of Contract drawings to be furnished the Contractor for this purpose, or in any other form which is approved prior to the beginning of the work. They shall be available at all times during construction for reference by the City, and shall be delivered to the City prior to pre-final inspection.



**SECTION 4  
BID RESPONSE FORMAT**

**4.0 FORMAT**

Submittals shall be submitted in duplicate. Submit one (1) original, four (4) copies and one (1) electronic copy of the submittal on USB Drive. All required signatures shall be manual, in blue ink of an authorized representative who has the legal authority to bind the CONTRACTOR in contractual obligations. Each page of the bid should state the name of the CONTRACTOR, the bid number, and the page number. The City reserves the right to request additional data or material to support bid. All material submitted in response to the ITB will become the property of the City.

**LABEL EACH SECTION AS NUMBERED**

The proposal must be in the following format specifically addressing each criterion below:

**1. Company Information**

In response to this Proposal, all Contractors must provide the following:

- Name of Agency/Company (including any "Doing Business As" names)
- Company Locations
- Internet Web Site Address (if any)
- Office address and telephone number, email address
- Proof of insurance
- Bidder must submit a copy of Florida Division of Corporations Sunbiz report with your company registered as **active**.
- W9
- Bonding Capacity Letter

**2. Qualifications**

Proposer's relevant experience, qualifications and past performance

- An explanation of why the Contractor is the best qualified to perform the contract and demonstrate its qualifications including an item-by-item disclosure outlining how the Contractor meets or exceeds the requirements of this ITB.
- Provide a brief introduction letter highlighting the overall experience and qualifications of the Respondent with respect to the services requested under this Solicitation. Project list demonstrating this minimum experience and shall include, at a minimum: the project, date of completion, base contract amount, number and amount of change orders, if any, the name, address, and phone number of the owner or owner's representative familiar with the work. Specifically list any projects, either complete or underway, that are located in Miami-Dade, Broward or Palm Beach, Florida Counties.
- **Bidder must address the Minimum Qualification Requirements A – D, per Section 2.2 of ITB.**



### 3. **Staffing**

Relevant experience and qualifications of key personnel, including key personnel of subcontractors, that will be assigned to this project and experience and qualifications of subcontractors

- The size and experience of the company staff pool from which staff assigned to the management contract can be drawn.
- The composition of the staff team that will be assigned to the contract.
- The names of the employees in the area responsible for this contract
- Their function in the company.
- The name of the person who will be responsible for the coordination of work.
- Experience and qualifications of staff and satisfactory record of performance of staff
- Each proposal must identify the name(s) and address(es) of all Subcontractors, suppliers and other persons and organizations including those who are to furnish the principal items of material and equipment. If requested by City after Bid Opening and before Award, the successful bidder shall submit to City additional detail on any or all Subcontractors or Suppliers including without limitation, pertinent information regarding similar projects, and other evidence of qualification for each such Subcontractor, Supplier, other persons or organization.

### 4. **Approach / Methodology**

Proposers approach methodology to providing the services requested in this solicitation must reference:

- Suitability of the methodologies and approaches used in achieving tasks.
- Overall organization to completing the project.
- Work plan explaining how they intend on meeting the established deadlines.
- Bidders are required to provide an Emergency Response Plan with 2 Hour Response for emergency call-outs (submit with bid).
- Bidder shall specify on the attached Bid Form the estimated response/mobilization time necessary to get crews working after contract award.
- Include information on Manufacturers' warranties
- Value engineering, if applicable
- Quality assurance and quality control (QA/QC) programs

### 5. **Corporate Standing and Authorized Signatory**

Respondent must demonstrate that the company is in good standing and that the person signing this submittal is an Authorized Signatory on behalf of the respondent to sign bids, proposals, negotiate and/or sign contracts, agreements, amendments and related documents to which the respondent will be duly bound. The respondent must provide a copy of the State Certificate of good standing listing the officers of the company. If the signatory is not one of the officers listed on the





State Certificate, the respondent must provide one of the following forms of evidence of Signatory Authority with its response:

- a. A copy of firm's Articles of Incorporation listing the approved signatories of the corporation;
- b. A copy of a resolution listing the members of staff as authorized signatories for the firm; and
- c. A letter from a corporate officer listing the members of staff that are authorized signatories for the firm.

6. **Litigation History**

CONTRACTOR shall provide a summary of any litigation or arbitration that the CONTRACTOR, its parent company or its subsidiaries have been engaged in or are currently engaged in, during the past five (5) years against or involving (1) any public entity in Florida for any amount (2) any private entity for an amount greater than \$100,000. The summary shall state the nature of the litigation or arbitration, a brief description of the case, the outcome or projected outcome, and the monetary amounts involved. The CITY may disqualify any CONTRACTOR it determines to be excessively litigious.

7. **Forms and Attachments**

Enclosed Forms;  
Respondent must complete, sign as required, and submit the Addenda and all forms; and Firm's Current Certificate(s) of Insurance.

8. **Exceptions**

Bidder must list any exceptions taken to the terms and condition in this ITB.



**QUALIFICATION REQUEST  
INCLUDE WITH YOUR BID**

**Contractor must list projects of similar project scope fulfilling the following qualification requests:**

1. List Project Management Personnel. Personnel cannot be changed without written approval.

Project Manager \_\_\_\_\_

2. How many years has your organization been in business as a Contractor?

\_\_\_\_\_

3. List current workload.

\_\_\_\_\_  
\_\_\_\_\_  
\_\_\_\_\_  
\_\_\_\_\_  
\_\_\_\_\_  
\_\_\_\_\_  
\_\_\_\_\_  
\_\_\_\_\_  
\_\_\_\_\_  
\_\_\_\_\_

4. Will you subcontract any part of this work? If so, give details to major key subcontractor's name, address, phone number and type of work to be performed. Also, indicate the percentage of the total work to be performed by the subcontractor.

\_\_\_\_\_  
\_\_\_\_\_  
\_\_\_\_\_  
\_\_\_\_\_  
\_\_\_\_\_  
\_\_\_\_\_



5. The business is a (sole proprietorship) (partnership) (corporation) and name of owner:

---

6. Has your company ever been debarred or terminated for default on a government contract?

---

7. Although not required, is your company a pre-qualified contractor through FDOT?

---

8. Identify your debris disposal plan.

---

---

---

---

---

9. Firm must list any exceptions taken to the terms and condition in this ITB.

---

---

---

10. Discuss what strategies the submitter will utilize to keep this project on schedule, considering long lead-times on fabrication. Please note, the city intends to award a contract and commence construction no earlier than the first week of June and to be completed no later than August 11, 2023. Due to long fabrication and delivery lead times, Contractor shall provide to the City a list of equipment required to maintain orderly progress of the Work and those required to order immediately upon NTP.

---

---

---



---

---

11. Discuss strategies the submitter will implement to ensure the project is kept on budget.

---

---

---

---

---

---

12. Have you personally inspected the plans and location, are there any concerns that may impede your performance on this project?

---

---

---

---

---

---

13. Describe the submitter's attributes, which make the submitter best-suited for this project.

---

---

---

**END OF SECTION**



## **REASON FOR “NO BID”**

For firms choosing **NOT** to bid/propose on this opportunity, the city appreciates your response using this form.

Please return via email to [Purchasing@sibfl.net](mailto:Purchasing@sibfl.net).

Why did your firm choose not to respond to this opportunity?

Circle all that apply from below list: \_\_\_\_\_

- a. We do not offer these services or equivalent.
- b. Insufficient time to respond to the solicitation.
- c. Our project schedule would not permit us to perform.
- d. Unable to meet requirements.

Other:



**DELIVER TO:**  
City of Sunny Isles Beach  
City Clerk  
18070 Collins Avenue  
Sunny Isles Beach, FL 33160

**INVITATION TO BID  
SECTION 5  
BID SUBMITTAL FORMS**

**OPENING: 11:00 A.M.  
MARCH 28, 2023**

PLEASE QUOTE PRICES FURNISHED & INSTALLED, LESS TAXES, PROVIDED TO  
CITY OF SUNNY ISLES BEACH, FLORIDA

NOTE: City of Sunny Isles Beach is exempt from all taxes (Federal, State, and Local). Bid price should be less all taxes. Tax Exemption Certificate furnished upon request.

---

Issued by:	Purchasing Manager: Genesis Cuevas	Date Issued: February 22, 2023	This ITB Submittal Consists of this ITB, Attachments and Exhibits
------------	---------------------------------------	-----------------------------------	-------------------------------------------------------------------------

---

Sealed bids are subject to the Terms and Conditions of this INVITATION TO BID and the accompanying Bid Submittal. Such other contract provisions, specifications, drawings or other data as are attached or incorporated by reference in the Bid Submittal, will be received at the office of the City Clerk at the address shown above until the above stated time and date, and at that time, publicly opened for furnishing the supplies or services described in the accompanying Bid Submittal Requirement.

**ITB 23-02-01  
EAST END OF 172<sup>nd</sup> STREET ROADWAY AND DRAINAGE IMPROVEMENTS**

**A bid bond in the amount of 10% of the total amount of the bid will be required with your bid.**

A Performance Bond in the amount of **100%** of the total amount of the bid will be required upon execution of the contract by the successful firm and City of Sunny Isles Beach

**Firm Name:**

---

**RETURN ONE ORIGINAL, FOUR COPIES AND ONE USB RESPONSE IN A SEALED ENVELOPE**



**SECTION 6  
BID SUBMITTAL FOR:**

**ACKNOWLEDGEMENT OF ADDENDA**

---

**INSTRUCTIONS: COMPLETE PART I OR PART II, WHICHEVER APPLIES**

---

**PART I:**

LIST BELOW ARE THE DATES OF ISSUE FOR EACH ADDENDUM RECEIVED IN CONNECTION WITH THIS BID

Addendum #1, Dated \_\_\_\_\_

Addendum #2, Dated \_\_\_\_\_

Addendum #3, Dated \_\_\_\_\_

Addendum #4, Dated \_\_\_\_\_

Addendum #5, Dated \_\_\_\_\_

Addendum #6, Dated \_\_\_\_\_

Addendum #7, Dated \_\_\_\_\_

Addendum #8, Dated \_\_\_\_\_

---

**PART II:  NO ADDENDUM WAS RECEIVED IN CONNECTION WITH THIS BID**

---

**FIRM NAME:** \_\_\_\_\_

**AUTHORIZED SIGNATURE:** \_\_\_\_\_ **DATE:** \_\_\_\_\_

**TITLE OF OFFICER:** \_\_\_\_\_



## BID SUBMITTAL FORM

### **Bid Title: 172nd STREET ROADWAY AND DRAINAGE IMPROVEMENTS**

The undersigned Bidder proposes and agrees, if this Bid is accepted, to enter into an agreement with The City of Sunny Isles Beach to perform and furnish all Work as specified or indicated in the Contract Documents for the Contract Price and within the Contract Time indicated in this Bid and in accordance with the other terms and conditions of the Contract Documents.

The Bidder accepts all of the terms and conditions of the Advertisement or INVITATION TO BID and Instructions to Proposers, including without limitation those dealing with the disposition of Bid Security. This Bid will remain subject to acceptance for 90 days after the day of Bid opening. The Proposer agrees to sign and submit the Agreement with the Bonds and other documents required by the Bidding Requirements within ten days after the date of the City's Notice of Award.

In submitting this Bid, the Proposer represents, as more fully set forth in the Agreement, that:

- The Proposer has familiarized himself/herself with the nature and extent of the Contract Documents, Work, site, locality, and all local conditions and Law and Regulations that in any manner may affect cost, progress, performance, or furnishing of the Work.
- The Proposer has given the City written notice of all conflicts, errors, discrepancies that it has discovered in the Contract Documents and the written resolution thereof by City is acceptable to the Proposer.
- This Bid is genuine and not made in the interest of or on behalf of any undisclosed person, firm or corporation and is not submitted in conformity with any agreement or rules of any group, association, organization, or corporation; the Proposer has not directly or indirectly induced or solicited any other Proposers to submit a false or sham Bid; the Proposer has not solicited or induced any person, firm or corporation to refrain from Bidding; and Proposer has not sought by collusion to obtain for itself any advantage over any other Proposers or over the City.

The Proposer understands and agrees that the Bid is for unit prices to furnish and install individual Work Items for maintenance and/or repair work, complete in place. Estimates are provided for the purposes of Bid Evaluation and to establish unit prices for individual Work to be contracted by the City under individual Purchase Orders, based on the unit prices established under this Bid.

The City and the successful Proposer will establish completion times for each individual Work Item and the successful Proposer agrees that the work will be completed within the time frames agreed upon and stipulated in the individual Purchase Orders and/or Notice to Proceed.





Firm Name: \_\_\_\_\_

Street Address: \_\_\_\_\_

Mailing Address (if different): \_\_\_\_\_

Telephone No. \_\_\_\_\_ Fax No. \_\_\_\_\_

Email Address: \_\_\_\_\_ FEIN No. \_\_\_/\_\_\_-\_\_\_/\_\_\_/\_\_\_/\_\_\_/\_\_\_/\_\_\_

***\* "By signing this document the bidder agrees to all Terms and conditions of this INVITATION TO BID.***

**Signature:**

\_\_\_\_\_  
**(Signature of authorized agent)**

Print Name: \_\_\_\_\_

Title: \_\_\_\_\_

**THE EXECUTION OF THIS FORM CONSTITUTES THE UNEQUIVOCAL OFFER OF PROPOSER TO BE BOUND BY THE TERMS OF ITS PROPOSAL. FAILURE TO SIGN THIS SOLICITATION WHERE INDICATED ABOVE BY AN AUTHORIZED REPRESENTATIVE SHALL RENDER THE PROPOSAL NON-RESPONSIVE. THE CITY MAY, HOWEVER, IN ITS SOLE DISCRETION, ACCEPT ANY PROPOSAL THAT INCLUDES AN EXECUTED DOCUMENT WHICH UNEQUIVOCALLY BINDS THE PROPOSER TO THE TERMS OF ITS OFFER.**



## ATTACHMENT A - PLANS



# 172ND STREET ROADWAY AND DRAINAGE IMPROVEMENTS

Sunny Isles Beach, Florida 33160

## ATTACHMENT A

LEGAL SURVEY NOTES:

1. EASEMENTS AND RIGHTS-OF-WAY PER RECORD PLAT HAVE BEEN SHOWN HEREON. NO FURTHER SEARCH FOR MATTERS OF RECORD HAS BEEN MADE BY THIS FIRM.
2. THE BOUNDARY SURVEY OF THE REAL PROPERTY DEPICTED ON THIS SURVEY REPRESENTS THE PROFESSIONAL OPINION OF THE UNDERSIGNED, BASED ON THE DESCRIPTION ATTACHED HEREON.
3. THE USE OF THE WORD "CERTIFY" AS USED HEREON IS AN EXPRESSION OF PROFESSIONAL OPINION AND DOES NOT CONSTITUTE A WARRANTY OR GUARANTEE.
4. THIS SURVEY IS NOT VALID WITHOUT THE SIGNATURE AND ORIGINAL SEAL OF A FLORIDA LICENSED PROFESSIONAL SURVEYOR AND MAPPER.
5. BENCHMARK REFERENCE - DADE COUNTY BENCHMARK# E-200 ELEVATION=5.35 NGVD29
6. ELEVATIONS SHOWN ARE REFERENCED TO NATIONAL GEODETIC VERTICAL DATUM OF 1929 (NGVD29).
7. THIS SURVEY REFLECTS OBSERVED EVIDENCE OF UTILITIES. LACKING EXCAVATION, THE EXACT LOCATION OF UNDERGROUND FEATURES CANNOT BE ACCURATELY AND COMPLETELY DEPICTED.
8. THIS SURVEY IS PREPARED FOR THE SOLE AND EXCLUSIVE USE OF THE PARTIES AS SURVEYED FOR AND AS CERTIFIED TO AND SHALL NOT BE RELIED UPON BY ANY OTHER ENTITY OR INDIVIDUAL.
9. HORIZONTAL CONTROL DATA RELATIVE TO FLORIDA STATE PLANE COORDINATE SYSTEM, EAST ZONE, NORTH AMERICAN DATUM OF 1983 / 2011 ADJUSTMENT.
10. BEARINGS SHOWN HEREON ARE REFERENCED TO AN ASSUMED MERIDIAN OF NORTH 86°51'00"EAST FOR THE CENTERLINE LINE OF N.E. 172nd STREET.
11. FOR 2 STRUCTURES (STORM DRAINAGE VAULTS @ STATIONS 11+10 AND 14+15) FULL OF WATER PIPES WERE NOT VISIBLE INVERTS PER THE APOGEE SERVICES, INC. SURVEY.



LOCATION MAP

NOT TO SCALE

SEC. 11 TOWNSHIP 52 SOUTH RANGE 42 EAST

PREPARED FOR:

CITY OF SUNNY ISLES BEACH

SHEET #.	DWG#.	DRAWING TITLE
--	--	COVER SHEET
1	C-1	ROADWAY DRAINAGE PLAN & PROFILE
2	C-2	PAVING AND GRADING PLAN
3	C-3	ROADWAY CROSS SECTION
4	C-4	UTILITY ADJUSTMENT PLAN
5	C-5	PAVING AND MARKING PLAN
6	C-6	POLLUTION PREVENTION CONTROL PLAN

**BOARD OF CITY COMMISSIONERS**

MAYOR	LARISA SVECHIN
VICE MAYOR	JERRY JOSEPH
COMMISSIONER	JENIFFER VISCARRA
COMMISSIONER	ALEX LAMA
COMMISSIONER	FABIOLA STUYVESANT
CITY MANAGER	STAN MORRIS



18070 COLLINS AVENUE,  
SUNNY ISLES BEACH, FL 33160

100% CONSTRUCTION DOCUMENTS



17670 NW 78TH AVENUE, SUITE 214  
MIAMI, FLORIDA 33015  
PHONE: (786) 468-8304  
ROSSENGINEERS.COM  
CA No. 9808



Call 811 or visit sunshine811.com two full business days before digging to have buried facilities located and marked. Check positive response codes before you dig!



## 1. APPLICABLE CODES

- 1.1. ALL CONSTRUCTION AND MATERIALS SHALL CONFORM TO THE STANDARD AND SPECIFICATIONS OF SUNNY ISLES BEACH AND ALL OTHER LOCAL, STATE AND NATIONAL CODES WHERE APPLICABLE EXCEPT WITHIN DEPARTMENT OF TRANSPORTATION (D.O.T.) R/W WHEREIN FLORIDA DEPARTMENT OF TRANSPORTATION (F.D.O.T.) GOVERNS.
- 1.2. ALL CONSTRUCTION SHALL BE DONE IN A SAFE MANNER AND IN STRICT COMPLIANCE WITH ALL THE REQUIREMENTS OF FEDERAL OCCUPATIONAL SAFETY AND HEALTH ACT OF 1970, AND ALL STATE AND LOCAL SAFETY AND HEALTH REGULATIONS.
- 1.3. ALL ELEVATIONS SHOWN ON THE CONSTRUCTION DRAWINGS ARE BASED ON THE BM ELEV.=5.35' VERTICAL DATUM 1929, (NGVD29) UNLESS OTHERWISE NOTED.
- 1.4. NORTH MIAMI BEACH WATER AND MIAM-DADE WATER AND SEWER DEPARTMENT SEWER DEPARTMENT WATER AND SEWER SPECIFICATIONS SHALL DICATE WHEN IN CONFLICT WITH ANY OF THE FOLLOWING SPECIFICATIONS.
- 1.5. ALL MATERIALS AND CONSTRUCTION WITHIN THE R/W SHALL CONFORM TO THE D.O.T. "DESIGN STANDARDS" (2015) AND "STANDARD SPECIFICATIONS" (2015).
- 1.6. THE CONTRACTOR IS RESPONSIBLE FOR PROVIDING THE MAINTENANCE OF TRAFFIC (M.O.T.) PLAN PRIOR TO CONSTRUCTION. THE CONSULTANT'S ENGINEER SHALL ENSURE THAT THE M.O.T. PLAN FOR THE PROJECT CONFORMS WITH STANDARD INDEX SERIES 600, APPLICABLE INDEX FOR WORK BEING PERFORMED. THE CONTRACTOR SHALL ENSURE THE M.O.T. PLAN IS IMPLEMENTED EXACTLY AS APPROVED.

## 2. PRECONSTRUCTION RESPONSIBILITIES

- 2.5. UPON THE RECEIPT OF THE "NOTICE TO PROCEED", THE CONTRACTOR SHALL CONTACT THE ENGINEER OF RECORD AND ARRANGE A PRECONSTRUCTION CONFERENCE TO INCLUDE ALL INVOLVED GOVERNMENTAL AGENCIES, UTILITY OWNERS, THE OWNER AND THE ENGINEER OF RECORD.
- 2.6. THE CONTRACTOR SHALL OBTAIN A SUNSHINE STATE ONE CALL OF FLORIDA, INC. CERTIFICATION NUMBER AT LEAST 48 HOURS PRIOR TO BEGINNING ANY EXCAVATION, CALL 1-800-432-4770.
- 2.7. ALL UTILITY EASEMENTS TO BE SECURED PRIOR TO CONSTRUCTION (IF REQUIRED).
- 2.8. LOCATION OF EXISTING FACILITIES AS SHOWN ON CONSTRUCTION DRAWINGS ARE DRAIN FROM AVAILABLE RECORDS. THE ENGINEER ASSUMES NO RESPONSIBILITY FOR THE ACCURACY OF THE FACILITIES SHOWN OR FOR ANY FACILITY NOT SHOWN. THE CONTRACTOR SHALL VERIFY, IF POSSIBLE, THE ELEVATIONS AND LOCATIONS OF EXISTING FACILITIES PRIOR TO CONSTRUCTION. IF AN EXISTING FACILITY IS FOUND TO CONFLICT WITH THE PROPOSED CONSTRUCTION UPON EXCAVATION, THE CONTRACTOR SHALL IMMEDIATELY NOTIFY THE ENGINEER OF RECORD SO THAT APPROPRIATE MEASURES CAN BE TAKEN TO RESOLVE THE PROBLEM.
- 2.9. THE CONTRACTOR MUST CALL SUNNY ISLES BEACH AT LEAST 48 HOURS BEFORE ANY EXCAVATION WITHIN THE R/W TO DETERMINE THE LOCATION TO OF THE EXISTING TRAFFIC SIGNAL INTERCONNECT CABLE.

## 3. INSPECTIONS

- 3.1. THE CONTRACTOR SHALL NOTIFY SUNNY ISLES BEACH, AND ANY OTHER GOVERNMENTAL AGENCIES HAVING JURISDICTION AT LEAST 24 HOURS PRIOR TO BEGINNING CONSTRUCTION AND PRIOR TO THE INSPECTION OF THE FOLLOWING ITEMS, WHERE APPLICABLE:
  - 3.1.1. CLEARING AND FILLING
  - 3.1.2. STORM DRAINAGE SYSTEM
  - 3.1.3. SOD AND LANDSCAPING
  - 3.1.4. SUBGRADE
  - 3.1.5. LIMEROCK BASE
  - 3.1.6. ASPHALTIC CONCRETE
  - 3.1.7. SIDEWALK
  - 3.1.8. FINAL

## 4. SHOP DRAWINGS

- 4.1. PRIOR TO THEIR CONSTRUCTION OR INSTALLATION, SHOP DRAWINGS SHALL BE SUBMITTED TO AND APPROVED BY THE ENGINEER OF RECORD AND SUNNY ISLES BEACH FOR THE FOLLOWING: SANITARY MANHOLES, STORM DRAIN MANHOLES, CATCH BASINS, FIRE HYDRANTS, PIPING, VALVES AND ALL REQUIRED ACCESSORIES. IT IS THE RESPONSIBILITY OF THE CONTRACTOR TO OBTAIN ALL OTHER AGENCY APPROVALS IF REQUIRED.

## 5. TEMPORARY FACILITIES

- 5.1. TEMPORARY FACILITIES:
  - 5.1.1. IT SHALL BE THE CONTRACTOR'S RESPONSIBILITY TO ARRANGE FOR OR SUPPLY TEMPORARY WATER SERVICE, SANITARY FACILITIES AND ELECTRICITY.
- 5.2. TRAFFIC REGULATION:
  - 5.2.1. MAINTENANCE OF TRAFFIC IN THE PUBLIC RIGHTS-OF-WAY SHALL BE IN ACCORDANCE WITH MANUAL TRAFFIC CONTROL DEVICES (M.U.T.C.D.).
  - 5.2.2. ALL OPEN TRENCHES AND HOLES ADJACENT TO ROADWAYS OR WALKWAYS SHALL BE PROPERLY MARKED AND BARRICADED TO ASSURE THE SAFETY OF BOTH VEHICULAR AND PEDESTRIAN TRAFFIC.
  - 5.2.3. NO TRENCHES OR HOLES NEAR WALKWAYS, IN ROADWAYS OR THEIR SHOULDERS ARE TO BE LEFT OPEN DURING NIGHTTIME HOURS WITHOUT EXPRESS PERMISSION OF SUNNY ISLES BEACH.
  - 5.2.4. IT SHALL BE THE RESPONSIBILITY OF THE CONTRACTOR FOR ANY NECESSARY CONSTRUCTION, PAVEMENT MARKING AND SIGNAGE OR ANY PEDESTRIAN SIGNALIZATION AND/OR SIGNAL MODIFICATION TO ACCOMMODATE AN ALTERNATE SAFE WALK ROUTE.

## 6. STORM DRAINAGE

- 6.1. GENERAL:
  - 6.1.1. DISTANCES AND LENGTHS SHOWN ON PLANS ARE REFERENCED TO THE CENTER OF STRUCTURES.
- 6.2. MATERIALS:
  - 6.2.1. HIGH-DENSITY POLYETHYLENE (H.D.P.E.) SHALL MEET THE REQUIREMENTS OF ASTM F2619 / F2619M, LATEST REVISION.
  - 6.2.2. REINFORCED CONCRETE PIPE (R.C.P.) SHALL MEET THE REQUIREMENTS OF ASTM C-76, LATEST REVISION. RUBBER GASKETS OR OTHER MANUFACTURER SUPPLIED JOINT SEALER SHALL BE USED.
  - 6.2.3. CORRUGATED ALUMINUM PIPE (C.A.P.) SHALL BE HELICAL TYPE, CONFORMING TO ASTM B209 AND AASHTO M196, AS MANUFACTURED BY KAISER ALUMINUM, INC., OR APPROVED EQUAL. THE CORRUGATION PATTERN AND GAUGE SHALL BE AS FOLLOWS:

DIA.	CORRUGATION	GAUGE
12" to 21"	2 2/3" x 1/2"	16
24" to 27"	2 2/3" x 1/2"	16
30"	2 2/3" x 1/2"	14
36" to 54"	3" x 1"	14
60" to 78"	3" x 1"	12

- 6.2.4. PIPE COUPLINGS FOR C.A.P. SHALL BE 12" WIDE (MINIMUM) 24" FOR 60" DIAMETER OR LARGER. SPLIT BANDS OF THE SAME ALLOY AS THE PIPE MAY BE ONE GAUGE LIGHTER THAN THE PIPE. POLYURETHANE OR OTHER MANUFACTURER SUPPLIED SEALANT SHALL BE USED WITH THE COUPLINGS.
- 6.2.5. FIELD JOINTS IN THE PIPE SHALL BE MADE WITH ALUMINUM SPIRAL RIB PIPE FORMED FROM COILED ALUMINUM SHEETS AND SHALL CONFORM TO ASTM B2-09 AND AASHTO M196, AS APPROVED BY KAISER ALUMINUM, INC., OR APPROVED EQUAL.
- 6.2.6. ALL DRAINAGE CATCH BASINS AND STRUCTURES SHALL BE PRECAST CONCRETE AS MANUFACTURED BY U.S. PRECAST CORPORATION, UNLESS OTHERWISE NOTED ON THE PLANS. BLOCK CATCH BASINS WILL BE ALLOWED ONLY WITH APPROVAL OF THE ENGINEER.
- 6.3. INSTALLATION:
  - 6.3.1. PIPE SHALL BE PLACED ON A MINIMUM OF 8" STABLE GRANULAR MATERIAL FREE OF ROCK FORMATION AND OTHER FOREIGN CONTAMINANTS, AND CONSTRUCTED TO A UNIFORM GRADE AND LINE.
  - 6.3.2. BACKFILL MATERIAL SHALL BE WELL GRADED GRANULAR MATERIAL, WELL TAMPED TO A HEIGHT OF 12 INCHES ABOVE PIPE AS SHOWN ON THE PLANS. TAMPING TO BE DONE IN LAYERS NOT TO EXCEED 12 INCHES.
  - 6.3.3. PROVIDE A MINIMUM PROTECTIVE COVER OF 18 INCHES OVER STORM SEWER AND AVOID UNNECESSARY CROSSING BY HEAVY CONSTRUCTION VEHICLES DURING CONSTRUCTION.
  - 6.3.4. THE CONTRACTOR SHALL NOTIFY SUNNY ISLES BEACH ENGINEERING DIVISION AT LEAST 7 DAYS PRIOR TO THE START OF THE CONSTRUCTION AND INSPECTION.

## 7. PAVING AND SIDEWALKS

- 7.1. GENERAL:
  - 7.1.1. ALL MUCK AND YIELDING MATERIAL WITHIN THE LIMITS OF CONSTRUCTION SHALL BE REMOVED AND REPLACED WITH CLEAN FILL MATERIAL WHICH SHALL BE COMPACTED AND SHAPED TO CONFORM TO THE REQUIRED SECTION. COMPACTED AREAS, AS SHOWN ON THE PLANS AND OR AS DETERMINED BY THE ENGINEER, SHALL BE COMPACTED TO NOT LESS THAN 98% OF MAXIMUM DENSITY AT OPTIMUM MOISTURE, AS DETERMINED BY AASHTO T-180, LATEST REVISION. AREAS TO BE STABILIZED, AS DETERMINED BY THE ENGINEER, SHALL HAVE A MINIMUM LBR=40.
  - 7.1.2. ALL UNDERGROUND UTILITIES SHALL BE COMPLETED PRIOR TO CONSTRUCTION OF LIMEROCK BASE.
  - 7.1.3. ALL EXISTING PAVEMENT, CUT OR DAMAGED BY CONSTRUCTION, SHALL BE PROPERLY RESTORED AT THE CONTRACTOR'S EXPENSE.
  - 7.1.4. WHERE ANY PROPOSED PAVEMENT IS TO BE CONNECTED TO EXISTING PAVEMENT, THE EXISTING EDGE OF PAVEMENT SHALL BE SAW CUT.
- 7.2. MATERIALS:
  - 7.2.1. BASE COURSE SHALL BE CRUSHED LIMEROCK WITH A MINIMUM OF 70% CARBONATES OF CALCIUM AND MAGNESIUM.
  - 7.2.2. ASPHALT SURFACES SHALL BE TYPE S-III ASPHALTIC CONCRETE, UNLESS OTHERWISE SPECIFIED ON THE PLANS. TWO (2) SHALL BE A MINIMUM OF 2" THICK, A AND SHALL BE APPLIED IN (2) 2" LIFTS.
  - 7.2.3. MINIMUM SIDEWALK CONSTRUCTION SHALL BE 4 INCH THICK CONCRETE, MINIMUM 3000psi COMPRESSIVE STRENGTH. SAWCUT CONSTRUCTION JOINTS 5 FOOT O.C. WITHIN 48 HOURS OF PLACING. EXPANSION JOINTS SHALL BE 20 FOOT O.C.
  - 7.2.4. CURBS AND GUTTERS: CONCRETE 3000psi COMPRESSIVE STRENGTH AT 28 DAYS, SAWCUT CONSTRUCTION JOINTS 10 FOOT O.C. WITHIN 48 HOURS OF PLACING.
  - 7.2.5. REINFORCED CONCRETE SLABS SHALL BE CONSTRUCTED OF CLASS I CONCRETE WITH A MINIMUM STRENGTH OF 3,000 PSI AND SHALL BE REINFORCED WITH A 6" x 6" NO. 10 GAUGE WIRE MESH.
- 7.3. INSTALLATION:
  - 7.3.1. SUBGRADE FOR PAVEMENT AREAS SHALL BE COMPACTED TO A MINIMUM OF 98% OF THE MAXIMUM DENSITY (AASHTO T-99(c)), AND SHALL HAVE A MINIMUM LBR 40.
  - 7.3.2. BASE COURSE MATERIAL FOR PAVED AREAS SHALL BE AS SHOWN ON PLANS FOR VARIOUS LOCATIONS.
  - 7.3.3. BASE COURSE MATERIAL FOR CURBS AND GUTTERS SHALL BE A MINIMUM THICKNESS OF 6 INCH.
  - 7.3.4. BASE COURSE SHALL BE COMPACTED TO 98% OF THE MAXIMUM DENSITY AS PER AASHTO T-180 AND SHALL HAVE A MINIMUM LBR OF 100.
  - 7.3.5. INSTALLATION OF THE WEARING SURFACE SHALL CONFORM WITH THE REQUIREMENTS OF THE D.O.T. STANDARD SPECIFICATIONS FOR TYPE S-3 ASPHALTIC CONCRETE.
- 7.4. TESTING:
  - 7.4.1. THE FINISHED SURFACE OF THE BASE COURSE AND THAT OF THE WEARING SURFACE SHALL NOT VARY MORE THAN 1/4" FROM THE TEMPLATE. ANY IRREGULARITIES EXCEEDING THIS LIMIT SHALL BE CORRECTED.
  - 7.4.2. DENSITY TESTS SHALL BE TAKEN BY AN INDEPENDENT TESTING LABORATORY CERTIFIED BY THE STATE OF FLORIDA, WHERE DIRECTED BY THE ENGINEER.
  - 7.4.3. ALL TESTING COSTS (PAVING) SHALL BE PAID FOR BY THE CONTRACTOR.
  - 7.4.4. DENSITY TESTS ON THE STABILIZED SUBGRADE SHALL BE SUPPLIED TO THE ENGINEER OF RECORD AND APPROVED BEFORE ANY LIMEROCK BASE IS CONSTRUCTED.
  - 7.4.5. DENSITY TESTS AND AS-BUILTS ON THE FINISHED LIMEROCK BASE SHALL BE SUPPLIED TO THE ENGINEER OF RECORD, AND APPROVED BEFORE ANY ASPHALT PAVEMENT IS CONSTRUCTED.

## 8. PROJECT CLOSEOUT

- 8.1. CLEANING UP:
  - 8.1.1. DURING CONSTRUCTION, THE PROJECT SITE AND ALL ADJACENT AREAS SHALL BE MAINTAINED IN A NEAT AND CLEAN MANNER, AND UPON FINAL CLEAN-UP, THE PROJECT SITE SHALL BE LEFT CLEAR OF ALL SURPLUS MATERIAL OR TRASH. THE PAVED AREAS SHALL BE SWEEP BROOM CLEAN.
  - 8.1.2. THE CONTRACTOR SHALL RESTORE OR REPLACE, WHEN AND AS DIRECTED, ANY PUBLIC OR PRIVATE PROPERTY DAMAGED BY HIS WORK, EQUIPMENT, OR EMPLOYEES, TO A CONDITION AT LEAST EQUAL TO THAT EXISTING IMMEDIATELY PRIOR TO THE BEGINNING OF OPERATIONS. TO THAT END, THE CONTRACTOR SHALL DO, AS REQUIRED, ALL NECESSARY HIGHWAY, DRIVEWAY, WALK AND LANDSCAPING WORK. SUITABLE MATERIALS AND METHODS SHALL BE USED FOR SUCH RESTORATION.
  - 8.1.3. WHERE MATERIAL OR DEBRIS HAS WASHED OR FLOWED INTO OR HAS BEEN PLACED IN WATER COURSES, DITCHES, DRAINS, CATCH BASINS, OR

ELSEWHERE AS A RESULT OF THE CONTRACTOR'S OPERATIONS, SUCH MATERIAL OR DEBRIS SHALL BE REMOVED AND SATISFACTORILY DISPOSED OF DURING THE PROGRESS OF THE WORK, AND THE AREA KEPT IN A CLEAN AND NEAT CONDITION.

- 8.2. ALL PROPERTY MONUMENTS OR PERMANENT REFERENCES, REMOVED OR DESTROYED BY THE CONTRACTOR DURING CONSTRUCTION SHALL BE RESTORED BY A STATE OF FLORIDA REGISTERED LAND SURVEYOR AT THE CONTRACTOR'S EXPENSE.
- 8.3. ALL UNPAVED SURFACES DISTURBED AS A RESULT OF CONSTRUCTION ACTIVITIES SHALL BE RESTORED TO A CONDITION EQUAL TO OR BETTER THAN THAT WHICH EXISTED BEFORE THE CONSTRUCTION.

## 9. ENGINEER'S AS-BUILT REQUIREMENTS

- 9.1. AS-BUILTS OF WATER LINES SHALL INCLUDE THE FOLLOWING INFORMATION:
  - 9.1.1. TOP OF PIPE ELEVATIONS EVERY 100 LF.
  - 9.1.2. LOCATIONS AND ELEVATIONS OF ALL FITTINGS INCLUDING BENDS, TEES, GATE VALVES, DOUBLE DETECTOR CHECK VALVES, FIRE HYDRANTS, ETC.
  - 9.1.3. ALL THE INS TO EXISTING LINES SHALL BE AS-BUILT.
  - 9.1.4. THE ENDS OF ALL WATER SERVICES AT THE BUILDINGS OR HOMES SHALL BE AS-BUILT OR WHERE THE WATER SERVICE TERMINATES.
- 9.2. AS-BUILTS OF ALL GRAVITY SANITARY SEWER LINES SHALL INCLUDE THE FOLLOWING INFORMATION:
  - 9.2.1. RIMS, INVERTS AND LENGTH OF PIPING BETWEEN STRUCTURES AS WELL AS SLOPES.
  - 9.2.2. THE STUB ENDS OF ALL SEWER LATERALS SHALL BE LOCATED AND IF THERE ARE ANY CLEANDOUTS INSTALLED ON THE SEWER LATERALS THEN THE INVERT ELEVATION OF THESE CLEANDOUTS SHALL BE OBTAINED.
  - 9.2.3. LIFT STATION AS-BUILTS SHALL CONSIST OF TOP OF WET WELL ELEVATION, INVERT ELEVATION OF THE INCOMING LINE, BOTTOM OF THE WET WELL AND AS-BUILTS OF THE COMPOUND AREA.
- 9.3. AS-BUILTS OF ALL DRAINAGE LINES SHALL INCLUDE THE FOLLOWING INFORMATION:
  - 9.3.1. RIMS, INVERTS AND LENGTH OF PIPING BETWEEN STRUCTURES AND WEIR ELEVATIONS IF APPLICABLE.
  - 9.3.2. THE SIZE OF THE PIPING SHALL BE VERIFIED BY THE SURVEY CREW AT THE TIME OF AS-BUILT.
  - 9.3.3. DRAINAGE WELL STRUCTURE AS-BUILTS SHALL INCLUDE, BUT NOT BE LIMITED TO, TOP OF CASING ELEVATION, TOP AND BOTTOM ELEVATIONS OF THE BAFFLE WALLS, RIM ELEVATIONS AND INVERTS OF PIPING.
- 9.4. ALL ROCK AS-BUILTS FOR PARKING LOT AREAS SHALL CONSIST OF THE FOLLOWING:
  - 9.4.1. ROCK ELEVATIONS AT ALL HIGH AND LOW POINTS, AND AT ENOUGH INTERMEDIATE POINTS TO CONFIRM SLOPE CONSISTENCY.
  - 9.4.2. ROCK AS-BUILTS SHALL BE TAKEN AT ALL LOCATIONS WHERE THERE IS A FINISH GRADE ELEVATION SHOWN ON THE DESIGN PLANS.
  - 9.4.3. ALL CATCH BASIN AND MANHOLE RIM ELEVATIONS SHALL BE SHOWN.
  - 9.4.4. ELEVATIONS AROUND ISLAND AREAS WILL ALSO BE REQUIRED.
  - 9.4.5. WHERE CONCRETE IS TO BE USED AS A FINISHED PRODUCT FOR THE ROADWAY OR PARKING LOT ROCK AS-BUILTS WILL BE REQUIRED AS INDICATED ABOVE AS WELL AS AS-BUILTS ON THE FINISHED CONCRETE AT LOCATIONS WHERE THERE IS A FINISH GRADE ELEVATION SHOWN ON THE DESIGN PLANS. FOR AS-BUILTS SHALL BE TAKEN ON ALL PAVED AND UNPAVED SWALES, PRIOR TO PLACEMENT OF ASPHALT OR TOPSOIL/SOD, AT ENOUGH INTERMEDIATE POINTS TO CONFIRM SLOPE CONSISTENCY AND CONFORMANCE TO THE PLAN DETAILS.
- 9.5. RETENTION AREA AS-BUILT ELEVATIONS SHALL BE TAKEN AT THE BOTTOM OF THE RETENTION AREA AND AT THE TOP OF BANK, IF THERE ARE CONTOURS INDICATED ON THE DESIGN PLANS, THEN THEY SHALL BE AS-BUILTED AS WELL.
- 9.6. UPON COMPLETION OF THE WORK, THE CONTRACTOR SHALL PREPARE RECORD DRAWINGS, "AS-BUILTS", ON FULL SIZE, 24" X 36" REPRODUCIBLE MATERIAL, WHERE WATER AND SEWER INFORMATION ARE ON THE SAME PAGE THE WATER LINE SHALL BE AS-BUILT BY STATION AND OFFSET UTILIZING THE SANITARY SEWER SYSTEM AS THE BASE LINE. IF IT IS NOT PRACTICAL TO UTILIZE THE SEWER SYSTEM AS A BASE LINE THEN THE SURVEYOR SHALL CONTACT THE ENGINEER OF RECORD SO THAT A SUBSTITUTE BASELINE MAY BE CHOSEN. ALL RECORD DRAWING, "AS-BUILT", INFORMATION SHALL BE PUT ON THE LATEST ENGINEERING DRAWINGS. ONE (1) SET OF REPRODUCIBLE RECORD DRAWINGS, "AS-BUILTS", SHALL BE SUBMITTED ALONG WITH EIGHT (8) SETS OF BLUE OR BLACKLINE DRAWINGS. THESE DRAWINGS SHALL BE SIGNED AND SEALED BY A FLORIDA REGISTERED PROFESSIONAL LAND SURVEYOR. ADDITIONALLY, AN ELECTRONIC COPY OF THESE RECORD DRAWINGS, "AS-BUILTS", SHALL BE SUBMITTED TO THE ENGINEER OF RECORD IN AUTOCAD, VERSION 2014.

TRAFFIC GENERAL NOTES & CONDITIONS
1. ENGINEER SHALL VISIT SITE & VERIFY FILED CONDITIONS BEFORE PREPARING PROPOSED SIGNING & PAVEMENT MARKINGS PLANS.
2. CONTRACTOR SHALL BE RESPONSIBLE FOR THE REMOVAL OF ALL PAVEMENT MARKINGS AND SIGNS CONFLICTING WITH THE PROPOSED ROADWAY CONSTRUCTION.
3. CONTRACTOR SHALL BE RESPONSIBLE FOR THE INITIATION OF ALL PAVEMENT MARKING AND SIGNS AS SHOWN IN THE PLANS AND APPLICABLE TRAFFIC DESIGN STANDARDS.
4. CONTRACTOR SHALL BE RESPONSIBLE FOR MATCHING EXISTING PAVEMENT MARKINGS AT THE BEGINNING AND AT THE END OF THE PROJECT, AND AT ALL INTERSECTING WITH ALL STREETS.
5. CONTRACTOR SHALL BE RESPONSIBLE FOR THE INSTALLATION OF REFLECTIVE PAVEMENT MARKERS ALONG THE ENTIRE LENGTH OF THE PROJECT.
6. SIGN ASSEMBLY LOCATIONS SHOWN IN THE PLANS WHICH ARE IN CONFLICT WITH STREET LIGHTING UTILITATION, DRIVEWAYS, PEDESTRIAN RAMPS ETC. MAY BE ADJUSTED AN DIRECTED BY THE ENGINEER/ CONTRACTOR.

GRC	2/6/23				
DESIGNED BY	DATE				
GRC	2/6/23				
DRAWN BY	DATE				
RR	2/6/23				
CHECKED BY	DATE				
RR	2/6/23				
APPROVED BY	DATE	No.	DATE	REVISIONS	

**172ND STREET ROADWAY AND DRAINAGE IMPROVEMENTS**  
172ND STREET  
SUNNY ISLES BEACH, FLORIDA 33160



17670 NW 78TH AVENUE, SUITE 214  
MIAMI, FLORIDA 33015  
(786)468-8304 (305)392-1019 FAX  
CERTIFICATE OF AUTHORIZATION No. 9808



18070 COLLINS AVENUE,  
SUNNY ISLES BEACH, FL 33160

# 100% CONSTRUCTION DOCUMENTS

## GENERAL NOTES AND SPECIFICATIONS

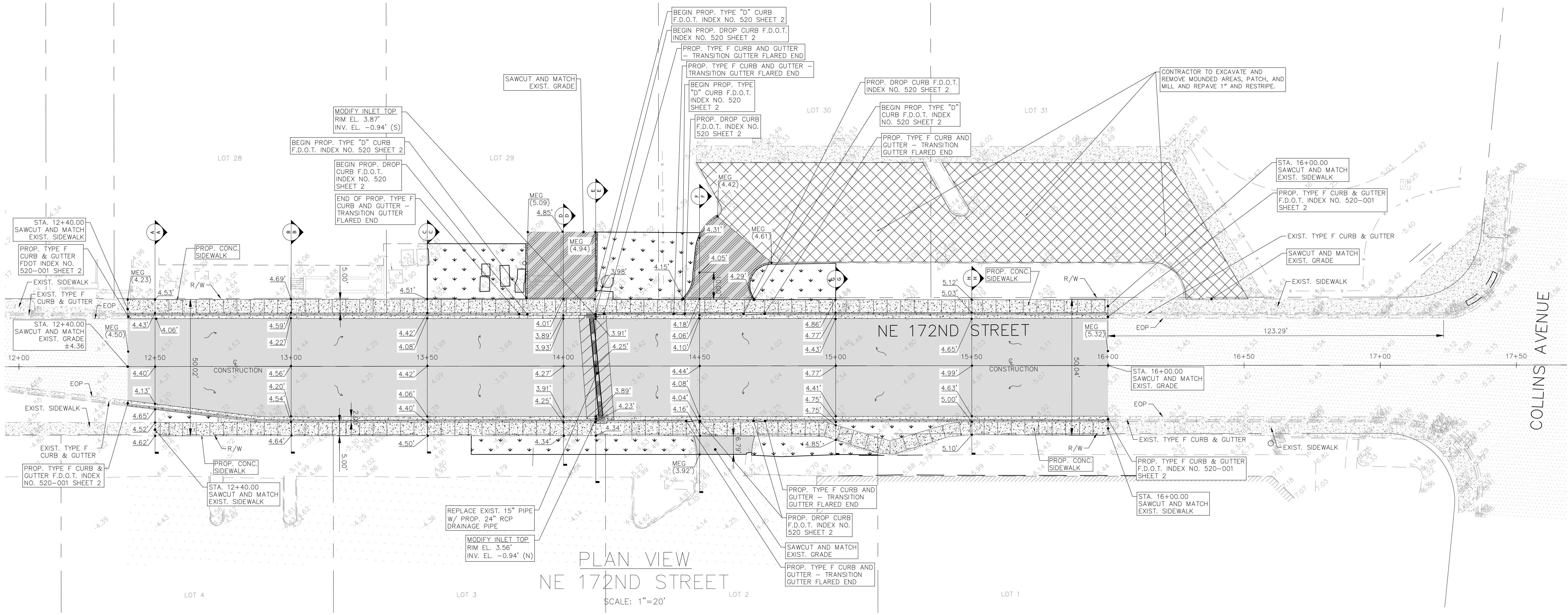
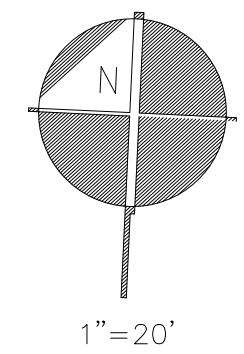

PLAN VIEW  
NE 172ND STREET  
SCALE: 1"=20'

LEGEND	
	PROPERTY LINE
	EXISTING BUILDING
	EXISTING ASPHALT
	EXISTING SIDEWALK TO REMAIN
	PROPOSED SOD
	REMOVE EXISTING ASPHALT AND REPLACE WITH 98% COMPACTED LIMEROCK BASE AND 4" TYPE S-III ASPHALT W/ 2-2" LIFTS
	PROPOSED 4" THICK CONCRETE SIDEWALK AND 6" THICK AT DRIVEWAY LOCATIONS
	PAVEMENT RESTORATION W/ 4" TYPE S-III ASPHALT W/ 2-2" LIFTS, 8" COMPACTED LIMEROCK BASE, 12" STABILIZED (LBR40) SUBGRADE
	PROPOSED GRADE
	MATCH EXISTING GRADE (MEG)
	FLOW ARROW
	PROPOSED CATCH BASIN (CB)
	PROPOSED DRAINAGE PIPE
	EXIST. ASPHALT TO EXCAVATE AND REMOVE MOUNDED AREAS, PATCH, AND MILL TO BE RESURFACED ALONG CITY PARK PROPERTY LIMITS WITH 1" TYPE S-III ASPHALT W/ 1-1" LIFTS
	REMOVE EXISTING ASPHALT AND REPLACE WITH 98% COMPACTED LIMEROCK BASE AND 1" TYPE S-III ASPHALT W/ 1-1" LIFTS

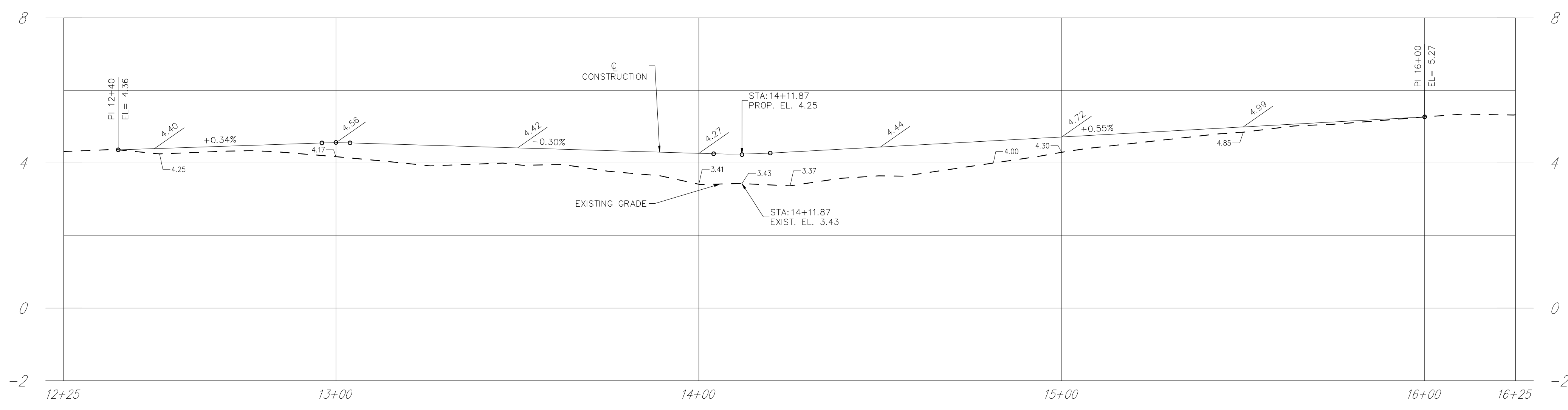

PROFILE VIEW  
NE 172ND STREET  
SCALE H 1"=20'  
V 1"=2'

- NOTES:**
- EXISTING UNDERGROUND UTILITIES SHOWN HEREON ARE APPROXIMATE LOCATIONS AND HAVE BEEN PREPARED FROM THE MOST RELIABLE INFORMATION AVAILABLE TO THE ENGINEER. CONTRACTOR SHALL BE RESPONSIBLE TO VERIFY LOCATION AND DEPTH OF ALL UNDERGROUND UTILITIES PRIOR TO COMMENCEMENT OF CONSTRUCTION.
  - CONTRACTOR TO FIELD VERIFY ANY CONFLICTS WITH TREES AND/OR UTILITIES AND DRAINAGE. CONTRACTOR TO NOTIFY ENGINEER OF ANY CONFLICTS BEFORE PROCEEDING WITH ANY SOLUTION TO THE CONFLICT.
  - CONTRACTOR SHALL TAKE ALL NECESSARY PRECAUTIONS TO SAFEGUARD ALL EXISTING STRUCTURES AND UTILITIES. ANY DAMAGE DONE TO EXISTING UTILITIES SHALL BE REPAIRED BY THE CONTRACTOR AT NOT EXPENSE TO THE SUBJECT UTILITY. CALL "SUNSHINE" 48 HOURS BEFORE DIGGING.
  - CONTRACTOR IS TO RESTORE ANY CURB, LANDSCAPE, ASPHALT, ETC. (NOT SCHEDULED FOR DEMOLITION) DAMAGED DURING CONSTRUCTION TO A CONDITION EQUAL TO WHAT IS EXISTING.
  - ALL EXISTING AND PROPOSED ELEVATIONS SHOWN ON THE CONSTRUCTION DOCUMENTS ARE BASED ON THE BM ELEV.=5.35' VERTICAL DATUM 1929 (NGVD29).

100% CONSTRUCTION DOCUMENTS

GRC	2/6/23			
DESIGNED BY	DATE			
GRC	2/6/23			
DRAWN BY	DATE			
RR	2/6/23			
CHECKED BY	DATE			
RR	2/6/23			
APPROVED BY	DATE	No.	DATE	REVISIONS

172ND STREET ROADWAY AND DRAINAGE IMPROVEMENTS  
172ND STREET  
SUNNY ISLES BEACH, FLORIDA 33160



17670 NW 78TH AVENUE, SUITE 214  
MIAMI, FLORIDA 33015  
(786)468-8304 (305)392-1019 FAX  
CERTIFICATE OF AUTHORIZATION No. 9808



ROADWAY DRAINAGE PLAN & PROFILE

SCALE: 1"=20'

SHEET No. C-2

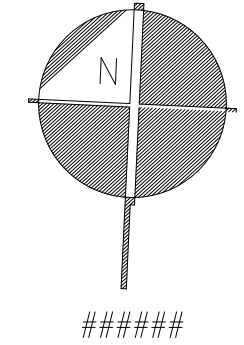

LEGEND	
	RIGHT-OF-WAY LINE
	EXISTING GRADE
	EXISTING SIDEWALK TO REMAIN
	PROPOSED SOD
	EXISTING ASPHALT LIMEROCK BASE
	REMOVE EXISTING ASPHALT AND REPLACE WITH 98% COMPACTED LIMEROCK BASE AND 2" TYPE S-III ASPHALT W/ 2-1" LIFTS
	PROPOSED 4" THICK CONCRETE SIDEWALK AND 6" THICK AT DRIVEWAY LOCATIONS
	EXISTING UNDERGROUND MATERIAL
	PAVEMENT RESTORATION W/ 2" TYPE S-III ASPHALT W/ 2-1" LIFTS, 8" COMPACTED LIMEROCK BASE, 12" STABILIZED (LBR40) SUBGRADE
	PROPOSED GRADE

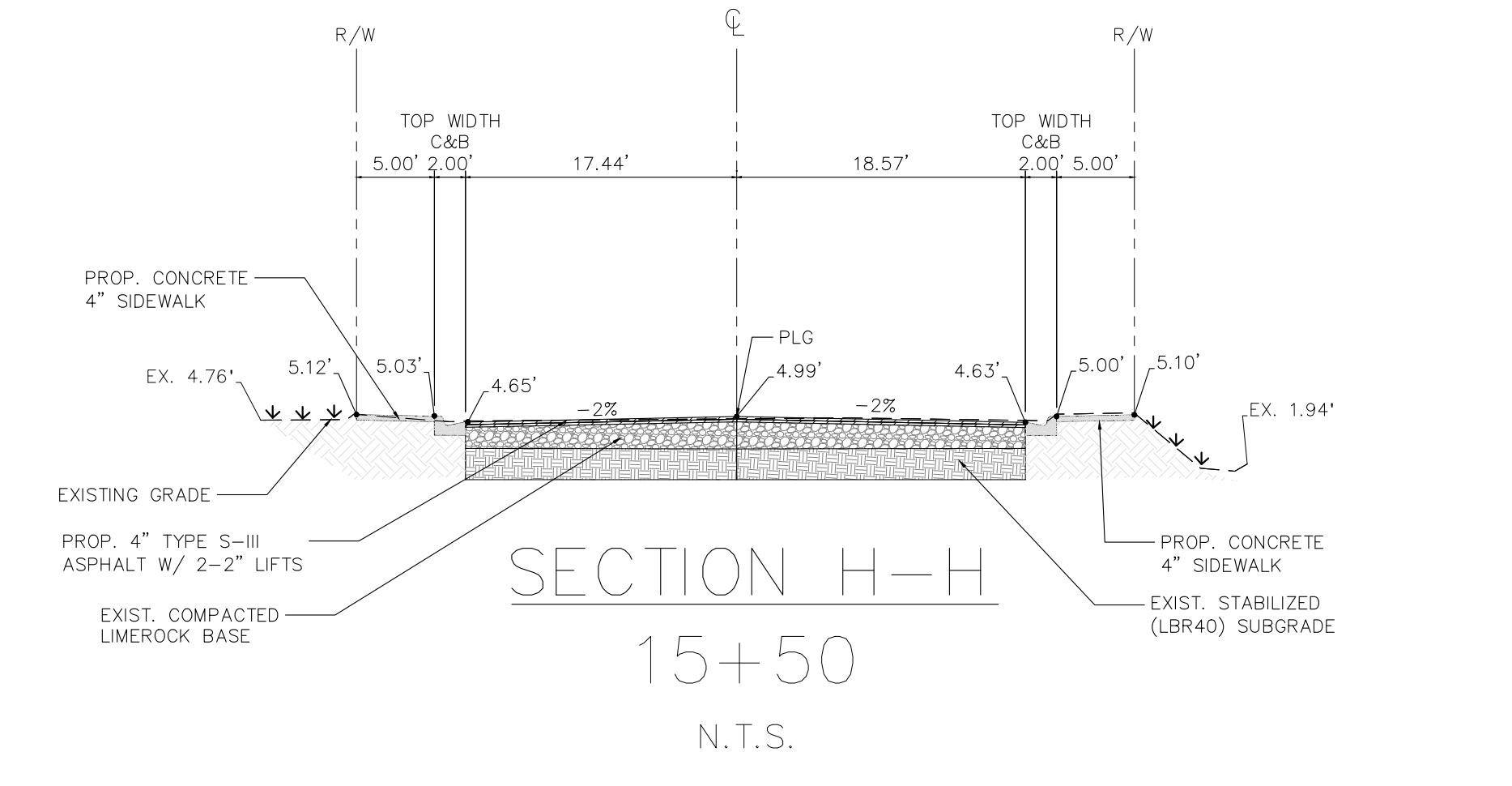
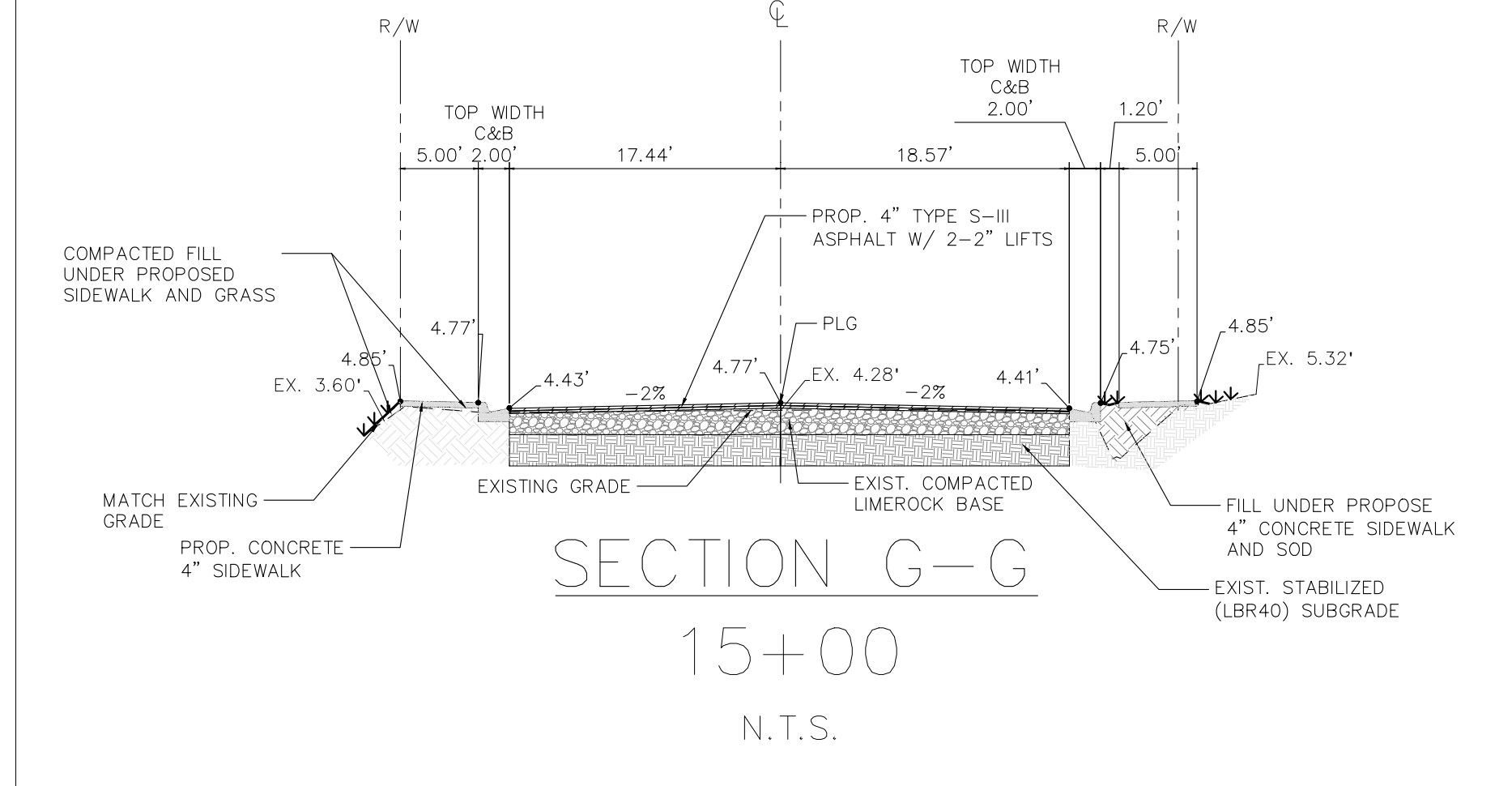
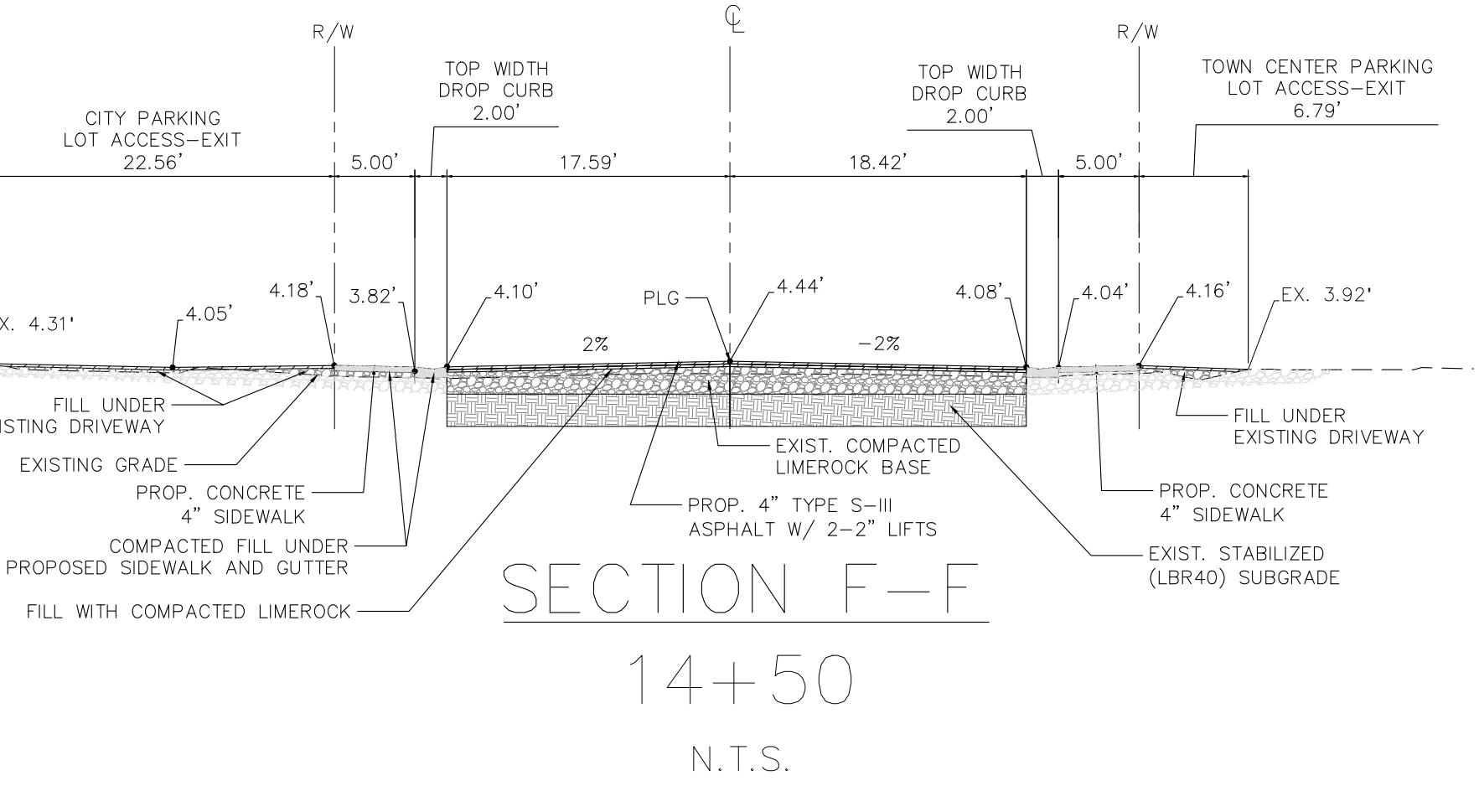
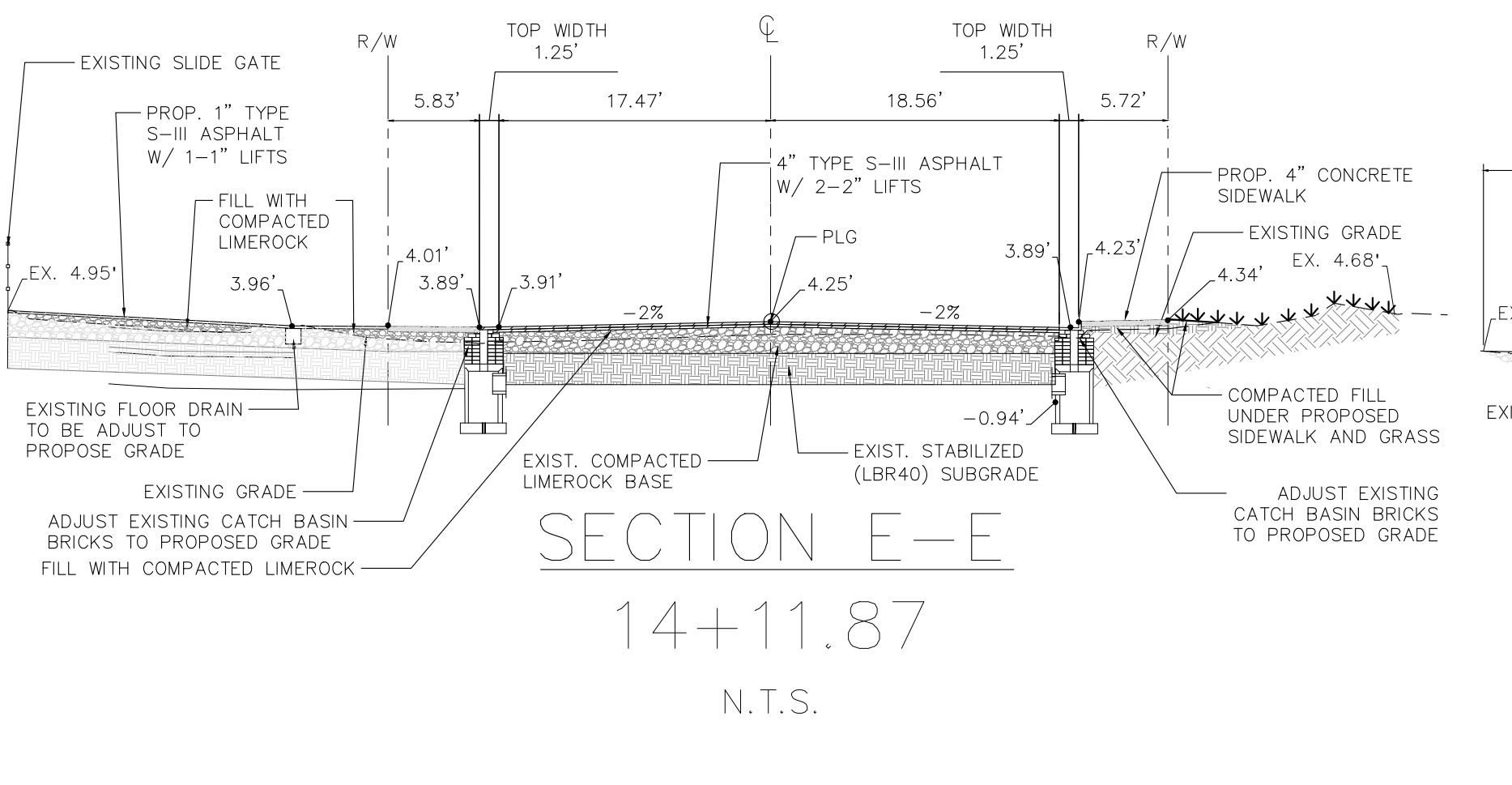
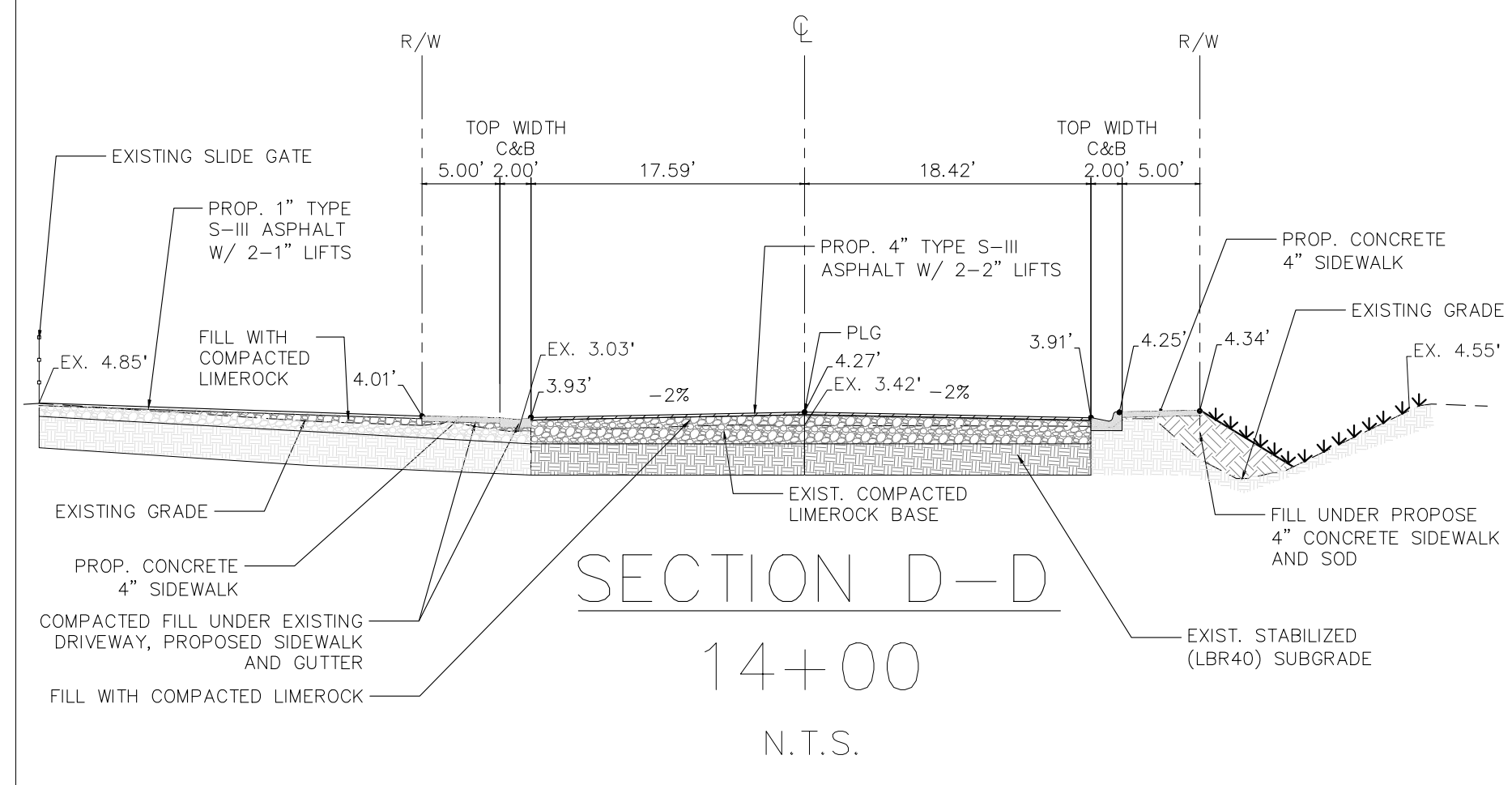
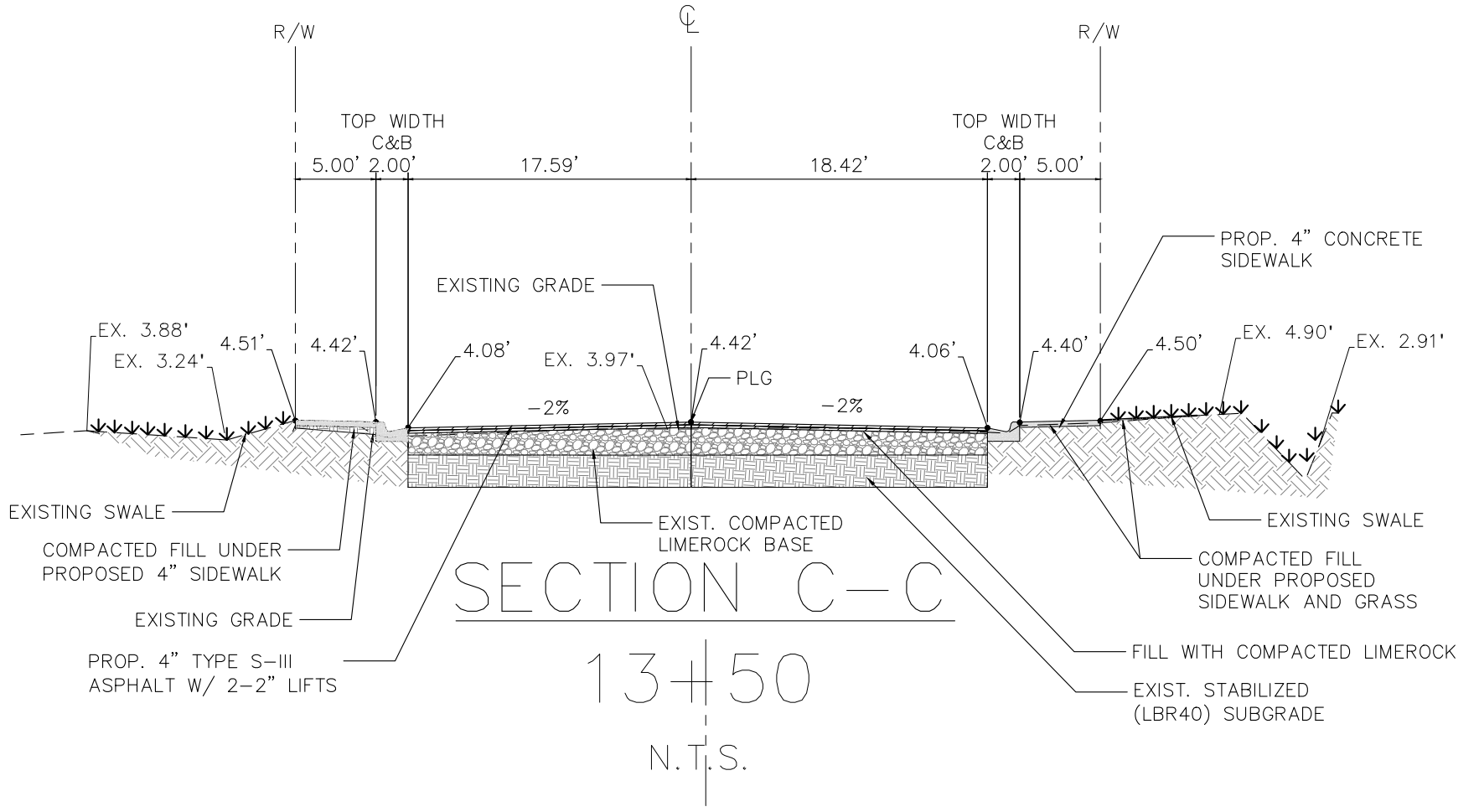
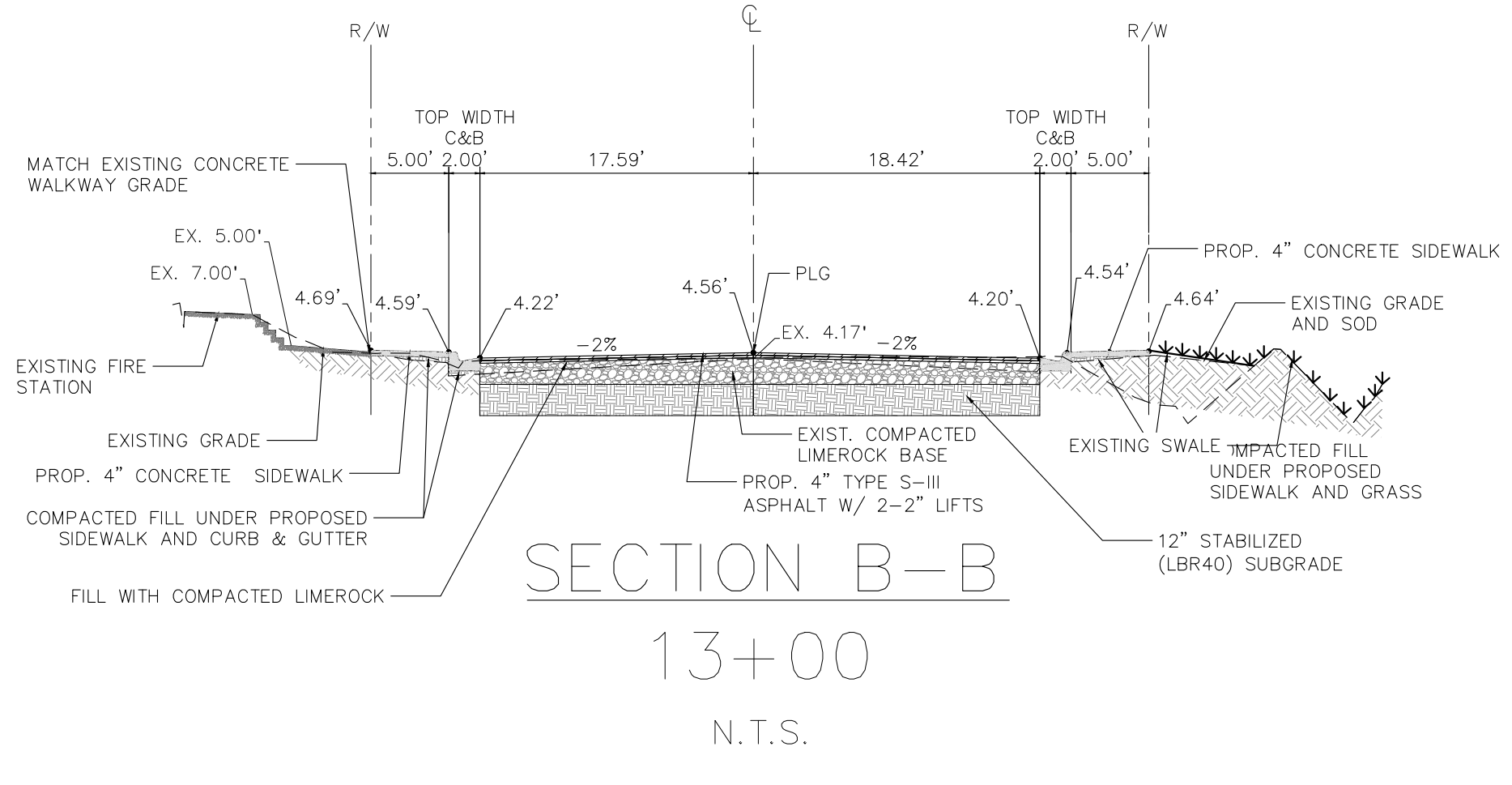
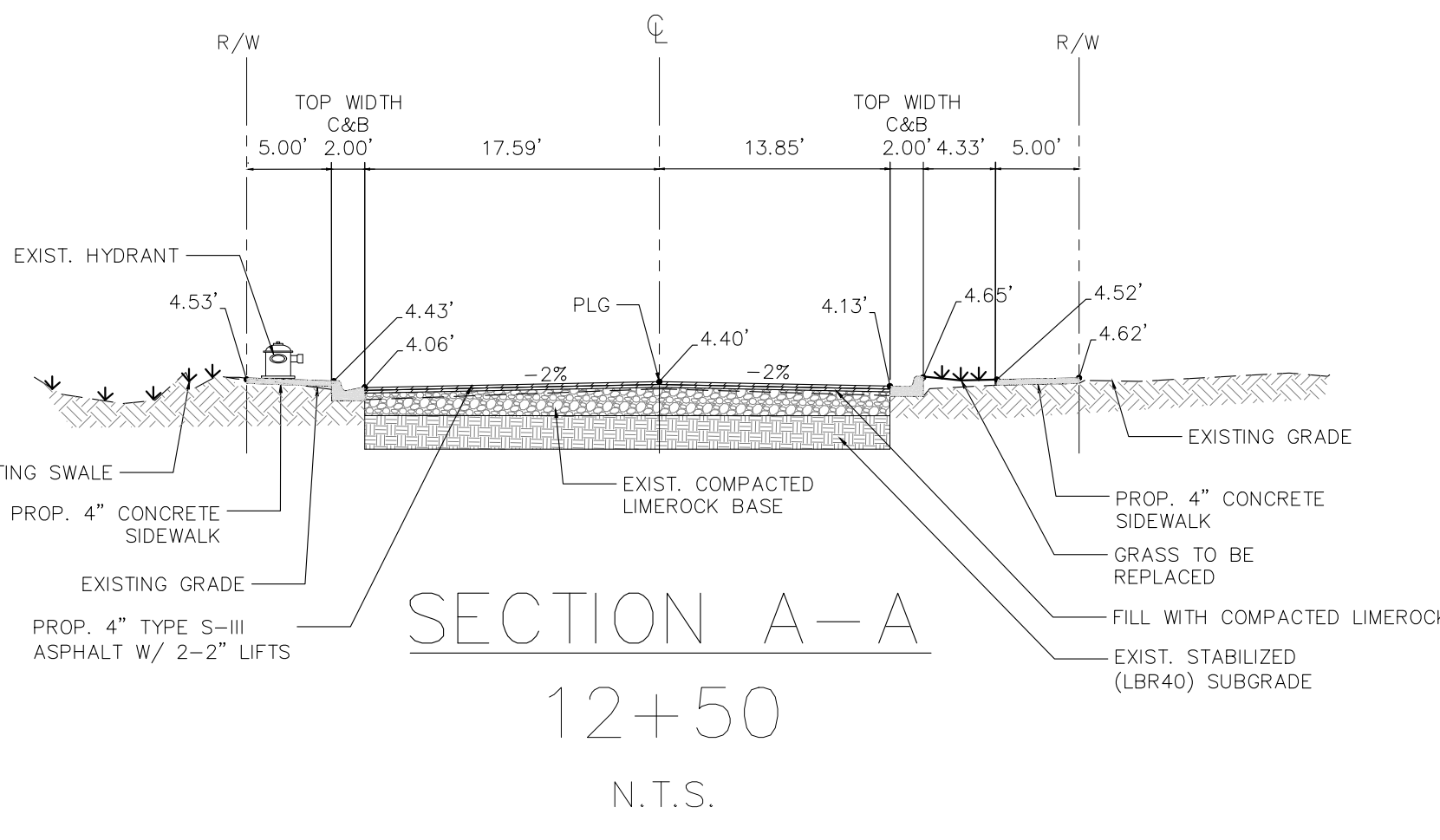

- NOTES:**
- EXISTING UNDERGROUND UTILITIES SHOWN HEREON ARE APPROXIMATE LOCATIONS AND HAVE BEEN PREPARED FROM THE MOST RELIABLE INFORMATION AVAILABLE TO THE ENGINEER. CONTRACTOR SHALL BE RESPONSIBLE TO VERIFY LOCATION AND DEPTH OF ALL UNDERGROUND UTILITIES PRIOR TO COMMENCEMENT OF CONSTRUCTION.
  - CONTRACTOR TO FIELD VERIFY ANY CONFLICTS WITH TREES AND/OR UTILITIES AND DRAINAGE. CONTRACTOR TO NOTIFY ENGINEER OF ANY CONFLICTS BEFORE PROCEEDING WITH ANY SOLUTION TO THE CONFLICT.
  - CONTRACTOR SHALL TAKE ALL NECESSARY PRECAUTIONS TO SAFEGUARD ALL EXISTING STRUCTURES AND UTILITIES. ANY DAMAGE DONE TO EXISTING UTILITIES SHALL BE REPAIRED BY THE CONTRACTOR AT NOT EXPENSE TO THE SUBJECT UTILITY. CALL "SUNSHINE" 48 HOURS BEFORE DIGGING.
  - CONTRACTOR IS TO RESTORE ANY CURB, LANDSCAPE, ASPHALT, ETC. (NOT SCHEDULED FOR DEMOLITION) DAMAGED DURING CONSTRUCTION TO A CONDITION EQUAL TO WHAT IS EXISTING.
  - ALL EXISTING AND PROPOSED ELEVATIONS SHOWN ON THE CONSTRUCTION DOCUMENTS ARE BASED ON THE BM ELEV.=5.35' VERTICAL DATUM 1929 (NGVD29).

**100% CONSTRUCTION DOCUMENTS**

GRC	2/6/23			
DESIGNED BY	DATE			
GRC	2/6/23			
DRAWN BY	DATE			
RR	2/6/23			
CHECKED BY	DATE			
RR	2/6/23			
APPROVED BY	DATE	No.	DATE	REVISIONS

**172ND STREET ROADWAY AND DRAINAGE IMPROVEMENTS**  
172ND STREET  
SUNNY ISLES BEACH, FLORIDA 33160



17670 NW 78TH AVENUE, SUITE 214  
MIAMI, FLORIDA 33015  
(786)468-8304 (305)392-1019 FAX  
CERTIFICATE OF AUTHORIZATION No. 9808



**ROADWAY CROSS SECTIONS**

SCALE: #####

SHEET No. C-3

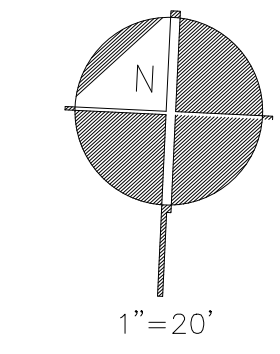

LEGEND	
	PROPERTY LINE
	EXISTING BUILDING
	EXISTING OVERHEAD LINE
	EXISTING WATER LINE
	EXISTING SANITARY SEWER LINE
	NUMBER AND APPROXIMATE LOCATION OF TEST BORING - 2 FT DEPTH WITH 3 INCH DIAMETER FOR SOIL PROFILE

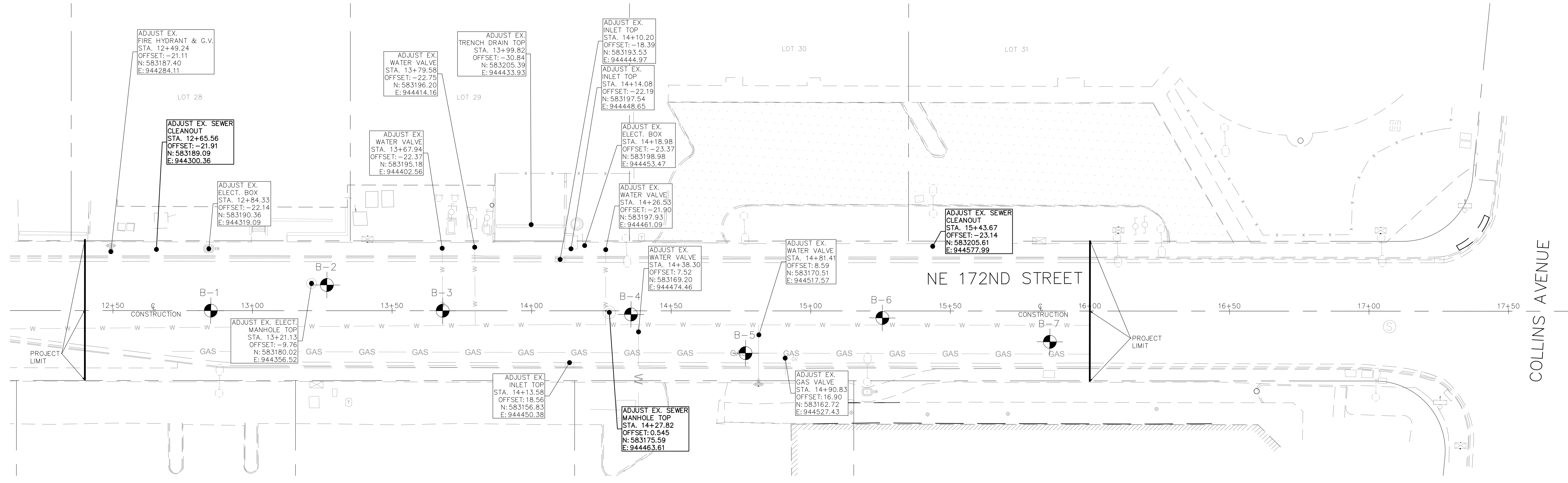

**MATERIAL TYPE:**  Asphalt  Sand  Mortar  Other: \_\_\_\_\_

**GENERAL LOCATION:**  Driveway  Road  Sidewalk  Curb

Other: \_\_\_\_\_

**SPECIFIC LOCATION:** At the intersection between 17200 Collins Avenue and 172nd street at Sunny Isle Beach

Soil Borings Details					
Boring	Depth	Soil Description	Offset from original loc.	Sample #	"N" value
1	0" - 4"	Asphalt	0'	1	20 22 24 20
	4" - 2'	Grayish fine to medium SAND and lime rock.			
2	0" - 4"	Asphalt	1' south from B-2	2	23 22 24 21
	4" - 2'	Grayish fine to medium SAND and lime rock.			
3	0" - 4"	Asphalt	0'	3	23 20 19 20
	4" - 2'	Grayish fine to medium SAND and lime rock.			
4	0" - 4"	Asphalt	0'	4	21 20 23 21
	4" - 2'	Grayish fine to medium SAND and lime rock.			
5	0" - 4"	Asphalt	2' north from B-5	5	20 22 21 24
	4" - 2'	Grayish fine to medium SAND and lime rock.			
6	0" - 4"	Asphalt	0'	6	19 21 22 24
	4" - 2'	Grayish fine to medium SAND and lime rock.			
7	0" - 4"	Asphalt	2' north from B-7	7	21 24 23 21
	4" - 2'	Grayish fine to medium SAND and lime rock.			

Comments: Boring B-2, B-5 and B-7 were offset due to traffic.  
 Borings were performed on 01/05/2023.  
 Limerock was present in the sample, with a ratio between 30% and 40%.

- NOTES:**
- EXISTING UNDERGROUND UTILITIES SHOWN HEREON ARE APPROXIMATE LOCATIONS AND HAVE BEEN PREPARED FROM THE MOST RELIABLE INFORMATION AVAILABLE TO THE ENGINEER. CONTRACTOR SHALL BE RESPONSIBLE TO VERIFY LOCATION AND DEPTH OF ALL UNDERGROUND UTILITIES PRIOR TO COMMENCEMENT OF CONSTRUCTION.
  - CONTRACTOR TO FIELD VERIFY ANY CONFLICTS WITH TREES AND/OR UTILITIES AND DRAINAGE. CONTRACTOR TO NOTIFY ENGINEER OF ANY CONFLICTS BEFORE PROCEEDING WITH ANY SOLUTION TO THE CONFLICT.
  - CONTRACTOR SHALL TAKE ALL NECESSARY PRECAUTIONS TO SAFEGUARD ALL EXISTING STRUCTURES AND UTILITIES. ANY DAMAGE DONE TO EXISTING UTILITIES SHALL BE REPAIRED BY THE CONTRACTOR AT NOT EXPENSE TO THE SUBJECT UTILITY. CALL "SUNSHINE" 48 HOURS BEFORE DIGGING.
  - CONTRACTOR IS TO RESTORE ANY CURB, LANDSCAPE, ASPHALT, ETC. (NOT SCHEDULED FOR DEMOLITION) DAMAGED DURING CONSTRUCTION TO A CONDITION EQUAL TO WHAT IS EXISTING.

GRC	2/6/23			
DESIGNED BY	DATE			
GRC	2/6/23			
DRAWN BY	DATE			
RR	2/6/23			
CHECKED BY	DATE			
RR	2/6/23			
APPROVED BY	DATE	No.	DATE	REVISIONS

**172ND STREET ROADWAY AND DRAINAGE IMPROVEMENTS**  
 172ND STREET  
 SUNNY ISLES BEACH, FLORIDA 33160



17670 NW 78TH AVENUE, SUITE 214  
 MIAMI, FLORIDA 33015  
 (786)468-8304 (305)392-1019 FAX  
 CERTIFICATE OF AUTHORIZATION No. 9808



100% CONSTRUCTION DOCUMENTS

UTILITY ADJUSTMENT PLAN

SCALE: 1"=20'

SHEET No.C-4

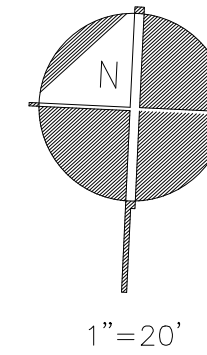

**Sunshine 811**  
 Call 811 or visit sunshine811.com two full business days before digging to have buried facilities located and marked. Check positive response codes before you dig!

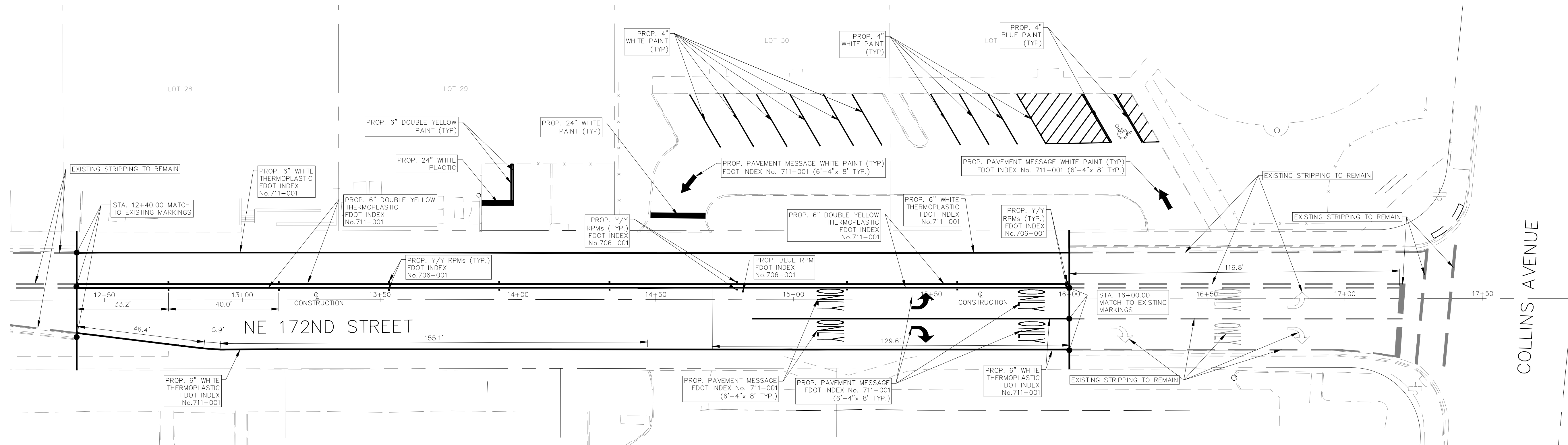

**100% CONSTRUCTION DOCUMENTS**

GRC	2/6/23			
DESIGNED BY	DATE			
GRC	2/6/23			
DRAWN BY	DATE			
RR	2/6/23			
CHECKED BY	DATE			
RR	2/6/23			
APPROVED BY	DATE	No.	DATE	REVISIONS

**172ND STREET ROADWAY AND DRAINAGE IMPROVEMENTS**  
 172ND STREET  
 SUNNY ISLES BEACH, FLORIDA 33160



17670 NW 78TH AVENUE, SUITE 214  
 MIAMI, FLORIDA 33015  
 (786)468-8304 (305)392-1019 FAX  
 CERTIFICATE OF AUTHORIZATION No. 9808



18070 COLLINS AVENUE,  
 SUNNY ISLES BEACH, FL 33160

**PAVING MARKING AND SIGNAGE**

SCALE: 1"=20'

SHEET No. c-5



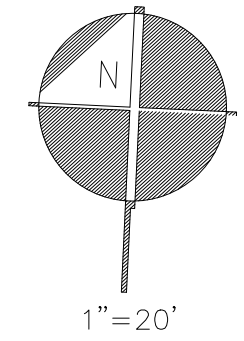

**Sunshine811**  
 Call 811 or visit sunshine811.com two full business days before digging to have buried facilities located and marked. Check positive response codes before you dig!

LEGEND	
	PROPERTY LINE
	SILT FENCE
	FILTER FABRIC

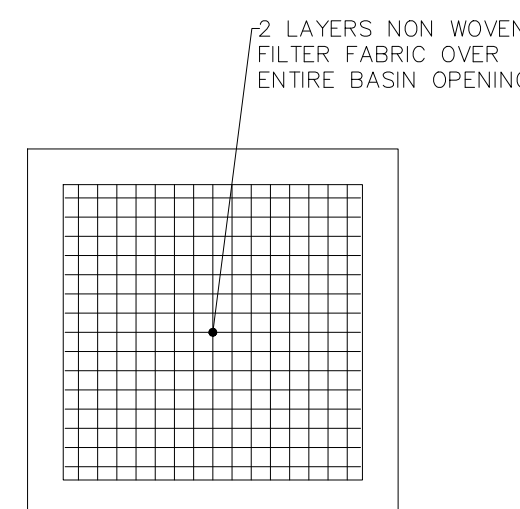
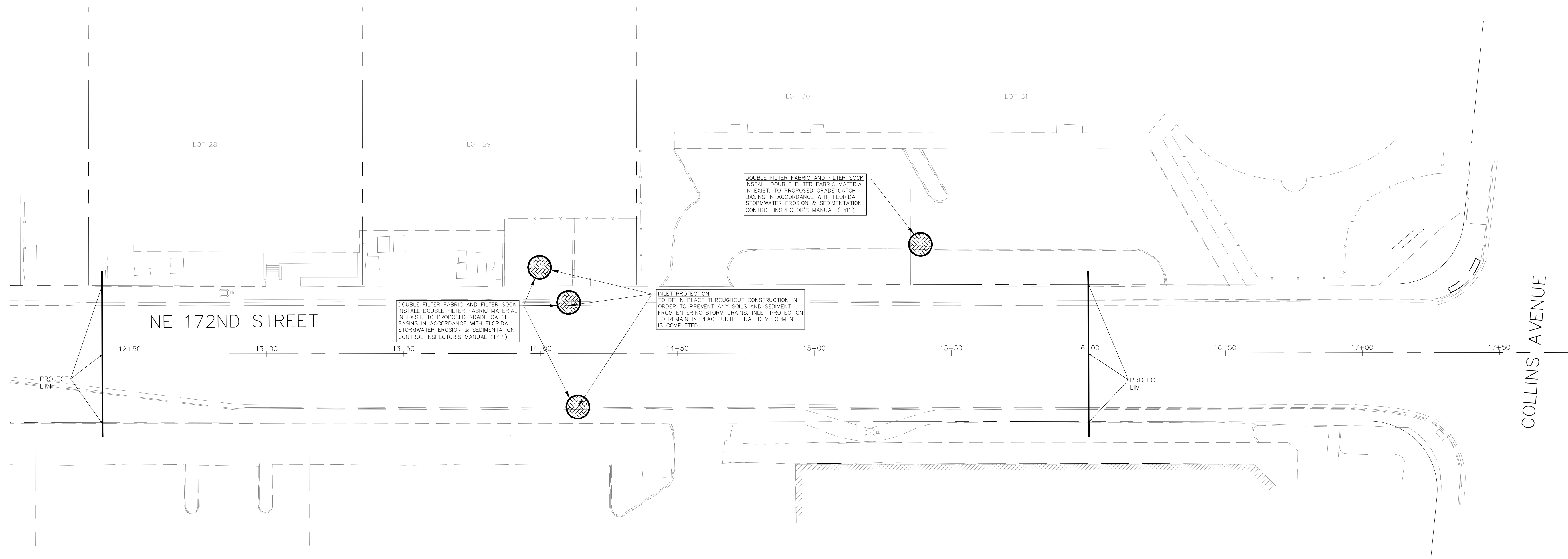

CATCH BASIN FILTER FABRIC  
 NTS

100% CONSTRUCTION DOCUMENTS

GRC	2/6/23			
DESIGNED BY	DATE			
GRC	2/6/23			
DRAWN BY	DATE			
RR	2/6/23			
CHECKED BY	DATE			
RR	2/6/23			
APPROVED BY	DATE	No.	DATE	REVISIONS

**172ND STREET ROADWAY AND DRAINAGE IMPROVEMENTS**  
 172ND STREET  
 SUNNY ISLES BEACH, FLORIDA 33160



17670 NW 78TH AVENUE, SUITE 214  
 MIAMI, FLORIDA 33015  
 (786)468-8304 (305)392-1019 FAX  
 CERTIFICATE OF AUTHORIZATION No. 9808



18070 COLLINS AVENUE,  
 SUNNY ISLES BEACH, FL 33160

**POLLUTION PREVENTION CONTROL PLAN**

SCALE: 1"=20'

SHEET No. c-6



## ATTACHMENT B – PRICE SHEET

- I. Bidder must use the Bid Price Sheet to submit Bidder's price for this Project.
- II. Bidder shall hold the unit Bid Prices firm throughout the Contract period. Bidder guarantees response time necessary to have a crew return to correct unfinished or unsatisfactory services.
- III. The City reserves the right to increase, decrease, and/or choose the items and quantities below for the Project to meet its available budget using the unit prices provided below.
- IV. Bidder must completely fill out each column below, i.e., unit price and total.
- V. Not applicable or "N/A" is not acceptable and will cause Bidder to be determined non-responsive. An authorized officer per the Bidders Sunbiz, must sign the Total Bid Price Sheet.
- VI. The award will be to the lowest responsive responsible Bidder for Total Bid Amount.





## Road, Drainage, Sidewalk & Pavement Markings

Description	Quantity	Unit	Unit Price	Total Price
GENERAL CONDITIONS/CONTRACT ADMINISTRATION (INSURANCE/INDEMNIFICATION)	1	LS		
CONSTRUCTION SURTEY BOND	1	LS		
MOBILIZATION / DEMOBILIZATION	1	LS		
NEW CURB TYPE "D"	101	LF		
NEW CURB AND GUTTER TYPE "F"	725	LF		
CONSTRUCTING NEW 4" THICK SIDEWALK TO MATCH EXISTING	3558	SF		
CONSTRUCTING BRICKS RISING UP TO NEW RIMS BOTTOM ELEVATION	3	EACH		
POLLUTION CONTROL STRUCTURES	3	EACH		
EXIST. ASPHALT TO BE RESURFACED ALONG CITY PARK PROPERTY LIMITS WITH 1" TYPE S-III ASPHALT W/ 1-1" LIFTS (AS SHOWN ON APPROVED PLANS)	7790	SF		
REMOVE EXISTING ASPHALT AND REPLACE WITH 98% COMPACTED LIMEROCK BASE AND 4" TYPE S-III ASPHALT W/ 2-2" LIFTS (AS SHOWN ON APPROVED PLANS)	12806	SF		
REMOVE EXISTING ASPHALT AND REPLACE WITH 98% COMPACTED LIMEROCK BASE AND 1" TYPE S-III ASPHALT W/ 1-1" LIFTS	1177	SF		
EXCAVATION FOR REMOVAL OF EXISTING DRAINAGE PIPE RCP	360	LF		
FOR RESTORATION SODDED AREA	2693	SF		
24" RCP	26	LF		
TOP RIM ADJUSTMENT FOR WATER VALVES, METER BOXES, ETC.	6	EACH		
TOP RIM ADJUSTMENT FOR SEWER STRUCTURES	3	EACH		
TOP RIM ADJUSTMENT FOR DRAINAGE STRUCTURES	4	EACH		
TOP RIM ADJUSTMENT FOR OTHERS UTILITIES (GAS, ELECT, ETC.)	4	EACH		
4" SINGLE WHITE PAINT (TYPICAL)	220	LF		
6" SINGLE WHITE THERMOPLASTIC (WITHIN THE R/W)	835	LF		
6" DOUBLE YELLOW PAINT (TYPICAL)	31	LF		
6" DOUBLE YELLOW THERMOPLASTIC (WITHIN THE R/W)	720	LF		
24" WHITE PAINT (TYP)	35	LF		
PAVEMENT MESSAGE WHITE PAINT (TYP) FDOT INDEX No. 711-001(6'-4" X 8' TYP.)	2	EACH		
PAVEMENT MESSAGE FDOT INDEX No. 711-001(6'-4" X 8' TYP.)	6	EACH		
HANDICAP BLUE PAINT	18	LF		
HANDICAP BLUE PAINT LOGO	1	EACH		
HANDICAP WHITE PAINT	274	LF		
Furnishing traffic control	1	Aggregate Sum		
Overhead and profit	1	Aggregate Sum		
			<b>SUBTOTAL</b>	<b>\$</b>

Providing uniformed, off-duty police officers for the purpose of maintenance of traffic	1	Aggregate Sum	N/A	\$ 60,000.00
Cost of required permits, fees, inspections, impact fees, if authorize by the Engineer (3% of Subtotal)	1	Dedicated Allowance	N/A	

<b>Grand Total</b>	<b>\$</b>
--------------------	-----------

- Notes:
- Quantities and structure types are subject to change based on final design and/or permitting effort.
  - Unit prices shall include all labor, materials, equipment, transportation, supervision representing an in-place price for each item.

**Signature**, I hereby attest that I have the authority to sign this notarized certification and certify that the above referenced information is true, complete and correct.



## AFFIDAVITS





**NON-COLLUSION AFFIDAVIT**

City of Sunny Isles Beach

18070 Collins Avenue

Sunny Isles Beach, FL 33160

Telephone: (305) 947-0606 Fax: (305) 949-3113

STATE OF FLORIDA )  
 )  
COUNTY OF \_\_\_\_\_ )

The undersigned being first duly sworn as provided by law, deposes, and says:

This Affidavit is made with the knowledge and intent that it is to be filed with the City of Sunny Isles Beach City Commission and that it will be relied upon by said County, in any consideration which may give to and any action it may take with respect to this Bid.

The undersigned is authorized to make this Affidavit on behalf of,

\_\_\_\_\_  
(Name of Corporation, Partnership, Individual, etc.)

a, \_\_\_\_\_, formed under the laws of \_\_\_\_\_  
(Type of Business) (State)

of which he is \_\_\_\_\_.  
(Sole Owner, Partner, President, etc.)

Neither the undersigned nor any person, firm, or corporation named in above Paragraph 10.2, nor anyone else to the knowledge of the undersigned, have themselves solicited or employed anyone else to solicit favorable action for this Bid by the City, also that no head of any department or employee therein, or any officer of the City of Sunny Isles Beach, Florida is directly interested therein.

This Bid is genuine and not collusive or a sham; the person, firm or corporation named above in Paragraph 10.2 has not colluded, conspired, connived or agreed directly or indirectly with any proposers or person, firm or corporation, to put in a sham Bid, or that such person, firm or corporation, shall refrain from Bidding, and has not in any manner, directly or indirectly, sought by agreement or collusion, or communication or conference with any person, firm or corporation, to fix the prices of said Bid or Bids of any other proposers; and all statements contained in the Bid or Bids described above true; and further; neither the undersigned, nor the person, firm or corporation named above in Paragraph 10.2, has directly or indirectly submitted said Bid or the contents thereof, or divulged information or data relative thereto, to any association or to any member or agent thereof.

\_\_\_\_\_  
AFFIANT'S NAME

\_\_\_\_\_  
AFFIANT'S TITLE

TAKEN, SWORN AND SUBSCRIBED TO BEFORE ME this \_\_\_\_ day of \_\_\_\_\_, 20\_\_\_\_

Personally Known \_\_\_\_\_ or Produced Identification \_\_\_\_\_;

Type of identification \_\_\_\_\_

(Affix seal here)

\_\_\_\_\_  
**NOTARY PUBLIC** (name printed or typed)



## PUBLIC ENTITY CRIMES

City of Sunny Isles Beach  
18070 Collins Avenue  
Sunny Isles Beach, FL 33160  
Telephone: (305) 947-0606 Fax: (305) 949-3113

### **SWORN STATEMENT PURSUANT TO SECTION 287.133(3)(a) FLORIDA STATUTES, ON PUBLIC ENTITY CRIMES**

#### **PUBLIC ENTITY CRIMES**

Pursuant to the provisions of paragraph (2) (a) of Section 287.133, Florida State Statutes - "A person or affiliate who has been placed on the convicted vendor list following a conviction for a public entity crime may not submit a Bid on a Contract to provide any goods or services to a public entity, may not submit a Bid on a Contract with a public entity for the construction or repair of a public building or public Work, may not submit Bids on leases of real property to a public entity, may not be awarded to perform Work as a Contractor, supplier, Sub-Contractor, or Consultant under a Contract with any public entity, and may not transact business with any public entity in excess of the threshold amount Category Two of Sec. 287.017, FS for thirty six months from the date of being placed on the convicted vendor list".

**THIS FORM MUST BE SIGNED AND SWORN TO IN THE PRESENCE OF A NOTARY PUBLIC OR OTHER OFFICIAL AUTHORIZED TO ADMINISTER OATHS.**

11.1. This sworn statement is submitted to City of Sunny Isles Beach

by \_\_\_\_\_  
[print individual's name and title]

for \_\_\_\_\_  
[print name of entity submitting sworn statement]

whose business address is:

\_\_\_\_\_  
\_\_\_\_\_

and (if applicable) its Federal Employer Identification number (FEIN) is \_\_\_\_\_.  
(If the entity had no FEIN, include the Social Security Number of the individual signing this sworn statement: \_\_\_\_\_.)

11.2. I understand that a "public entity crime" as defined in Paragraph 287.133(1)(g), Florida Statutes, means a violation of any state or federal law by a person with respect to and directly related to the transaction of business with any public entity or with an agency or political subdivision of any other state or with the United States, including, but not limited to, any Bid or Contract for goods or services to be provided to any public entity or an agency or political subdivision of any other state of the United States and involving antitrust, fraud, theft, bribery, collusion, racketeering, conspiracy, or material misrepresentation.

11.3. I understand that "convicted" or "conviction" as defined in Para. 287.133(1)(b), Florida Statutes, means a finding of guilt or a conviction of a public entity crime, with or without an adjudication of guilt, in any federal or state trial court of record relating to charges brought by indictment or information after July 1, 1989, as a result of a jury verdict, non-jury trial, or entry of a plea of guilty or nolo contendere.

11.4. I understand that an "affiliate" as defined in Para. 287.133(1)(a), Florida Statutes, means:

a.) predecessor or successor of a person convicted of a public entity crime; or

b.) Any entity under the control of any natural person who is active in the management of the entity and who has been convicted of a public entity crime. The term "affiliate" includes those officers, directors, executors, partners, shareholders, employees, members, and agents who are active in the management of an affiliate. The ownership by one person of shares constituting a controlling interest in another person, or a pooling of equipment or income among persons when not for fair

market value under an arm's length agreement, shall be a prime facie case that one person controls another person. A person who knowingly enters into a joint venture with a person who has been convicted of a public entity crime in Florida during the preceding 36 months shall be considered an affiliate.

**11.5.** I understand that a "person" as defined in Para. 287.133(1)(e), Florida Statutes, means any natural person or entity organized under the laws of any state or of the United States with the legal power to enter into a binding Contract and which Bids or applies to Bid on Contracts for the provision of goods or services let by a public entity, or which otherwise transacts or applies to transact business with a public entity. The term "persons" includes those officers, directors, executives, partners, shareholders, employees, members, and agents who are active in management of any entity.

**11.6.** Based on information and belief, the statement which I have marked below is true in relation to the entity submitting this sworn statement. (Indicate which statement applies.)

\_\_\_\_\_ Neither the entity submitting this sworn statement, nor any of it's officers, directors, executives, partners, shareholders, employees, members, or agents who are active in the management of the entity, nor any affiliate of the entity has been charged with and convicted of a public entity crime subsequent to July 1, 1989.

\_\_\_\_\_ The entity submitting this sworn statement, or one or more of its officers, directors, executives, partners, shareholders, employees, members, or agents who are active in the management of the entity, or an affiliate of the entity has been charged with and convicted of a public entity crime subsequent to July 1, 1989.

\_\_\_\_\_ The entity submitting this sworn statement, or one or more of its officers, directors, executives, partners, shareholders, employees, members, or agents who are active in the management of the entity, or an affiliate of the entity has been charged with and convicted of a public entity crime subsequent to July 1, 1989. However, there has been a subsequent proceeding before a Hearing Officer of the State of Florida, Division of Administrative Hearings and the Final Order entered by the Hearing Officer of the State of Florida, Division of Administrative Hearings and the Final Order entered by the Hearing Officer determined that it was not in the public interest to place the entity submitting this sworn statement on the convicted vendor list. (Attach a copy of the final order.)

I UNDERSTAND THAT THE SUBMISSION OF THIS FORM TO THE CONTRACTING OFFICER FOR THE PUBLIC ENTITY IDENTIFIED IN PARAGRAPH 11.1 (ONE) ABOVE IS FOR THAT PUBLIC ENTITY ONLY AND, THAT THIS FORM IS VALID THROUGH DECEMBER 31 OF THE CALENDAR YEAR IN WHICH IT IS FILED. I ALSO UNDERSTAND THAT I AM REQUIRED TO INFORM THE PUBLIC ENTITY PRIOR TO ENTERING INTO A CONTRACT IN EXCESS OF THE THRESHOLD AMOUNT PROVIDED IN SECTION 287.017, FLORIDA STATUTES, FOR CATEGORY TWO OF ANY, CHANGE IN THE INFORMATION CONTAINED IN THIS FORM.

By:

\_\_\_\_\_  
(Signature)

\_\_\_\_\_  
(Printed Name)

\_\_\_\_\_  
(Title)

Sworn to and subscribed before me this \_\_\_\_\_ day of \_\_\_\_\_, 20\_\_\_\_, by

\_\_\_\_\_  
(AFFIX NOTARY STAMP HERE)

Signature:  
\_\_\_\_\_

Personally Known \_\_\_\_\_ OR Produced Identification \_\_\_\_\_



EQUAL OPPORTUNITY /  
AFFIRMATIVE ACTION

City of Sunny Isles Beach  
18070 Collins Avenue  
Sunny Isles Beach, FL 33160  
Telephone: (305) 947-0606 Fax: (305) 949-3113

**EQUAL OPPORTUNITY/AFFIRMATIVE ACTION STATEMENT**

The contractors and all subcontractors hereby agree to a commitment to the principles and practices of equal opportunity in employment and to comply with the letter and spirit of federal, state, and local laws and regulations prohibiting discrimination based on race, color, religion, national region, sex, age, handicap, marital status, and political affiliation or belief.

Signed: \_\_\_\_\_

Title: \_\_\_\_\_

Firm: \_\_\_\_\_

Address: \_\_\_\_\_

\_\_\_\_\_





# CONFLICT OF INTEREST

City of Sunny Isles Beach  
18070 Collins Avenue  
Sunny Isles Beach, FL 33160  
Telephone: (305) 947-0606 Fax: (305) 949-3113

## **CONFLICT OF INTEREST STATEMENT**

The award of any contract hereunder is subject to the provisions of Chapter 112, Florida State Statutes. Proposers must disclose with their Bids, the name of any officer, director, partner, associate or agent who is also an officer or employee of the City of Sunny Isles Beach or its agencies.

STATE OF FLORIDA  
COUNTY OF \_\_\_\_\_

BEFORE ME, the undersigned authority, personally appeared \_\_\_\_\_, who was duly sworn, deposes, and states:

**18.1.** I am the \_\_\_\_\_ of \_\_\_\_\_ with a local office in \_\_\_\_\_ and principal office in \_\_\_\_\_.

**18.2.** The above named entity is submitting a Bid for the City of Sunny Isles Beach, Bid No. \_\_\_\_\_ described as: Golden Shores Street Lighting. The Affiant has made diligent inquiry and provides the information contained in this Affidavit based upon his own knowledge.

**18.3** The Affiant states that only one submittal for the above Bid is being submitted and that the above named entity has no financial interest in other entities submitting Bids for the same project.

**18.4** Neither the Affiant nor the above named entity has directly or indirectly entered into any agreement, participated in any collusion, or otherwise taken any action in restraints of free competitive pricing in connection with the entity's submittal for the above Bid. This statement restricts the discussion of pricing data until the completion of negotiations if necessary and execution of the Contract for this project.

**18.5** Neither the entity nor its affiliates, nor any one associated with them, is presently suspended or otherwise ineligible from participation in contract letting by any local, State, or Federal Agency.

**18.6** Neither the entity, nor its affiliates, nor any one associated with them have any potential conflict of interest due to any other clients, contracts, or property interests for this project.

**18.7** I certify that no member of the entity's ownership or management is presently applying for any employee position or actively seeking an elected position with the City of Sunny Isles Beach.

**18.8** I certify that no member of the entity's ownership or management, or staff has a vested interest in any aspect of the City of Sunny Isles Beach.

**18.9** In the event that a conflict of interest is identified in the provision of services, I, on behalf of the above named entity, will immediately notify the City of Sunny Isles Beach.

Dated this \_\_\_\_\_ day of \_\_\_\_\_, 2023.

\_\_\_\_\_  
AFFIANT

\_\_\_\_\_  
Print or Type Name and Title

Sworn to and subscribed before me this \_\_\_\_\_ day of \_\_\_\_\_, 2023..

Personally Known \_\_\_\_\_ OR  
 Produced Identification \_\_\_\_\_; Type of Identification \_\_\_\_\_

**NOTARY PUBLIC STATE OF FLORIDA**



## DISPUTE DISCLOSURE

City of Sunny Isles Beach  
18070 Collins Avenue  
Sunny Isles Beach, FL 33160  
Telephone: (305) 947-0606 Fax: (305) 949-3113

### **DISPUTE DISCLOSURE FORM**

**Answer the following questions by placing a "X" after "Yes" or "No". If you answer "Yes", please explain in the space provided, or on a separate sheet attached to this form.**

**19.1.** Has your firm or any of its officers, received a reprimand of any nature or been suspended by the Department of Professional Regulations or any other regulatory agency or professional associations within the last five (5) years?

YES \_\_\_\_\_ NO \_\_\_\_\_

**19.2.** Has your firm, or any member of your firm, been declared in default, terminated or removed from a contract or job related to the services your firm provides in the regular course of business within the last five (5) years?

YES \_\_\_\_\_ NO \_\_\_\_\_

**19.3.** Has your firm had against it or filed any requests for equitable adjustment, contract claims, Bid protests, or litigation in the past five (5) years that is related to the services your firm provides in the regular course of business?

YES \_\_\_\_\_ NO \_\_\_\_\_ If yes, state the nature of the request for equitable adjustment, contract claim, litigation, or protest, and state a brief description of the case, the outcome or status of the suit and the monetary amounts of extended contract time involved.

I hereby certify that all statements made are true and agree and understand that any misstatement or misrepresentation or falsification of facts shall be cause for forfeiture of rights for further consideration of this Bid for the City of Sunny Isles Beach.

\_\_\_\_\_  
Firm

\_\_\_\_\_  
Date

\_\_\_\_\_  
Authorized Signature

\_\_\_\_\_  
Print or Type Name and Title





# CONTRACTOR ANTI-BOYCOTT CERTIFICATION

[PURSUANT TO FLORIDA STATUTE § 215.4725]

I, \_\_\_\_\_, on behalf of \_\_\_\_\_,  
Print Name Company Name

certifies that \_\_\_\_\_ does not:  
Company Name

1. Participate in a boycott of Israel; and
2. Is not on the Scrutinized Companies that Boycott Israel list; and
3. Is not on the Scrutinized Companies with Activities in Sudan List; and
4. Is not on the Scrutinized Companies with Activities in the Iran Petroleum Energy Sector List; and
5. Has not engaged in business operations in Cuba or Syria.

\_\_\_\_\_  
Signature

\_\_\_\_\_  
Title

\_\_\_\_\_  
Date



## PERFORMANCE BOND

City of Sunny Isles Beach  
18070 Collins Avenue  
Sunny Isles Beach, FL 33160  
Telephone: (305) 947-0606 Fax: (305) 949-3113

### **FORM OF PERFORMANCE BOND**

KNOW ALL MEN BY THESE PRESENTS:

That, pursuant to the requirements of Florida Statute 255.05, we, \_\_\_\_\_, as Principal, hereinafter called Contractor, and \_\_\_\_\_, as Surety, are bound to the City of Sunny Isles Beach, Florida, as Obligee, hereinafter called City, in the amount of \_\_\_\_\_ Dollars (\$\_\_\_\_\_) for the payment whereof Contractor and Surety bind themselves, their heirs, executors, administrators, successors and assigns, jointly and severally.

WHEREAS, Contractor has by written agreement entered into a Contract, Bid/Contract No, awarded the day of \_\_\_\_\_, 20\_\_\_\_, with \_\_\_\_\_ in accordance with contract documents prepared by the City of Sunny Isles Beach, which Contract is by reference made a part hereof, and is hereafter referred to as the Contract;

THE CONDITION OF THIS BOND is that if the Contractor:

1. Fully performs the Contract between the Contractor and the City for services described within (Bid No. \_\_\_\_\_) within \_\_\_\_\_ calendar days after the date of Contract commencement as specified in the Notice to Proceed and in the manner prescribed in the Contract; and
2. Indemnifies and pays City all losses, damages (specifically including, but not limited to, damages for delay and other consequential damages caused by or arising out of the acts, omissions or negligence of Contractor), expenses, costs and attorney's fees including attorney's fees incurred in appellate proceedings, that City sustains because of default by Contractor under the Contract; and
3. Upon notification by the City corrects any and all defective or faulty Work or materials which appear within one and one half (1 1/2) years, and:
4. Performs the guarantee of all Work and materials furnished under the Contract for the time specified in the Contract, then this Bond is void, otherwise it remains in full force. Whenever Contractor shall be, and declared by City to be, in default under the Contract, the City having performed City's obligations there under, the Surety may promptly remedy the default, or shall promptly:
  - 4.1. Complete the Contract in accordance with its terms and conditions; or
  - 4.2. Obtain a Bid or Bids for completing the Contract in accordance with its terms and conditions, and upon determination by Surety of the best, lowest, qualified, responsible and responsive Proposers, or, if the City elects, upon determination by the City, and Surety jointly of the best, lowest, qualified, responsible and responsive Proposers, arrange for a Contract between such Proposers and City, and make available as Work progresses (even though there should be a default or a succession of defaults under the Contract or Contracts of completion arranged under this paragraph) sufficient funds to pay the cost of completion less the balance of the Contract Price; but not exceeding, including other costs and damages for which the Surety may be liable hereunder, the amount set forth in the first paragraph hereof. The term "balance of the Contract Price." as used in this paragraph, shall mean the total amount payable by City to Contractor under the Contract and any amendments thereto, less the amount properly paid by City to Contractor.

No right of action shall accrue on this Bond to or for the use of any person or corporation other than the City named herein.

The Surety hereby waives notice of and agrees that any changes in or under the Contract Documents and compliance or noncompliance with any formalities connected with the Contract or the changes do not affect Surety's obligation under this Bond.

Signed and sealed this \_\_\_\_\_ day of \_\_\_\_\_, 20\_\_\_\_\_.

**WITNESS:**

\_\_\_\_\_  
**Secretary**

**(CORPORATE SEAL)**

**BY:**

\_\_\_\_\_  
**(Name of Corporation)**

\_\_\_\_\_  
**(Signature)**

\_\_\_\_\_  
**(Type Name and Title Signed Above)**

**IN THE PRESENCE OF; INSURANCE COMPANY:**

**BY:**

\_\_\_\_\_  
**\*Agent and Attorney-in-Fact**

\* (Power of Attorney must be attached)

\_\_\_\_\_  
**(Address)**

\_\_\_\_\_  
**(City/State/Zip Code)**

\_\_\_\_\_  
**(Telephone)**

**STATE OF FLORIDA**

**COUNTY OF** \_\_\_\_\_

The foregoing instrument was acknowledged before me this \_\_\_\_\_ day of \_\_\_\_\_, 20\_\_\_\_, by \_\_\_\_\_ [name of person], as \_\_\_\_\_ [type of authority], for \_\_\_\_\_ [name of party on behalf of whom instrument was executed].

AFFIX NOTARY STAMP HERE:

\_\_\_\_\_  
**Signature: Notary Public – State of Florida**

\_\_\_\_\_  
Print or Type Commissioned Name

Personally Known \_\_\_\_\_ OR Produced Identification \_\_\_\_\_

Type of Identification Produced \_\_\_\_\_



# BID BOND

City of Sunny Isles Beach

18070 Collins Avenue

Sunny Isles Beach, FL 33160

Telephone: (305) 947-0606 Fax: (305) 949-3113

STATE OF FLORIDA )  
 )  
COUNTY OF \_\_\_\_\_)

KNOW ALL MEN BY THESE PRESENTS, that we, \_\_\_\_\_ as Principal, and \_\_\_\_\_ as Surety, are held and firmly bound unto the City of Sunny Isles Beach, a municipal corporation of the State of Florida in the sum of \_\_\_\_\_ Dollars (\$ \_\_\_\_\_), lawful money of the United States, for the payment of which sum well and truly to be made, we bind ourselves, our heirs, executors, administrators and successors jointly and severally, firmly by these presents.

THE CONDITION OF THIS OBLIGATION IS SUCH that whereas the Principal has submitted the accompanying Bid dated, \_\_\_\_\_ 2010 for:  
\_\_\_\_\_.

WHEREAS, it was a condition precedent to the submission of said Bid that a cashier's check or Bid Bond in the amount of **ten percent (10%)** of the Base Bid be submitted with said Bid as a guarantee that the Proposers would, if awarded the Contract, enter into a written Contract with the City for the performance of said Contract, within ten (10) consecutive calendar days after written notice having been given of the Award of the Contract.

NOW, THEREFORE, the conditions of this obligation are such that if the Principal within ten (10) consecutive calendar days after written notice of such acceptance, enters into a written Contract with the City of Sunny Isles Beach and furnishes the Performance Bond, satisfactory to the City, each in an amount equal to one hundred percent (100%) of the Contract Price, and provides all required Certificates of Insurance, then this obligation shall be void; otherwise the sum herein stated shall be due and payable to the City of Sunny Isles Beach and the Surety herein agrees to pay said sum immediately, upon demand of the City, in good and lawful money of the United States of America, as liquidated damages for failure thereof of said Principal.

IN WITNESS WHEREOF, the above bonded parties have executed this instrument under their several seals this \_\_\_\_\_ day of \_\_\_\_\_, 20\_\_\_\_, the name and the corporate seal of each corporate party being hereto affixed and these presents being duly signed by its undersigned representative.

DOCUMENT CONTINUES ON NEXT PAGE

IN PRESENCE OF:

\_\_\_\_\_  
Individual or Partnership Principal

\_\_\_\_\_  
Affix Corporate Seal

\_\_\_\_\_  
Business Address

\_\_\_\_\_  
City, State, and Zip Code

\_\_\_\_\_  
Business Telephone

\_\_\_\_\_  
Business Facsimile

ATTEST:

\_\_\_\_\_  
(Corporate Surety)\*

\_\_\_\_\_  
Secretary

\*Impress Corporate Seal

By:

IMPORTANT

Surety companies executing bonds must appear on the Treasury Department's most current list (circular 570 as amended) and be authorized to transact business in the State of Florida.

## **E-Verify Affidavit**

Florida Statute 448.095 directs all public employers, including municipal governments, to verify the employment eligibility of all new public employees through the U.S. Department of Homeland Security's E-Verify System, and further provides that a public employer may not enter into a contract unless *each* party to the contract registers with and uses the E-Verify system.

Florida Statute 448.095 further provides that if a contractor enters into a contract with a subcontractor, the subcontractor must provide the contractor with an affidavit stating that the subcontractor does not employ, contract with, or subcontract with an unauthorized alien.

In accordance with Florida Statute 448.095, all contractors doing business with the City of Sunny Isles Beach are required to verify employee eligibility using the E-Verify system for all existing and new employees hired by the contractor during the contract term. Further, the contractor must also require and maintain the statutorily required affidavit of its subcontractors. It is the responsibility of the awarded vendor to ensure compliance with E-Verify requirements (as applicable). To enroll in E-Verify, employers should visit the E-Verify website (<https://www.e-verify.gov/employers/enrolling-in-e-verify>) and follow the instructions. The contractor must, as usual, retain the I-9 Forms for inspection.

By affixing your signature below you hereby affirm that you will comply with E-Verify requirements.

\_\_\_\_\_  
Company Name

\_\_\_\_\_  
Offeror Signature

\_\_\_\_\_  
Date

\_\_\_\_\_  
Print Name

\_\_\_\_\_  
Title

\_\_\_\_\_  
Federal Employer Identification Number (FEIN)

### **Notary Public Information**

Sworn to and subscribed before me on this this \_\_\_\_\_ day of \_\_\_\_\_, 2023.

By \_\_\_\_\_

Is personally known to me

Has produced identification (type of identification produced: \_\_\_\_\_)

\_\_\_\_\_  
Signature of Notary Public

\_\_\_\_\_  
Print or Stamp of Notary Public

\_\_\_\_\_  
Expiration Date